

Design of Instrument Measurement for X-Ray Radiation with Geiger Muller

Georgia Kusmiran Barends, Bedjo Utomo, Tri Bowo Indrato

Department of Electromedical Engineering PoltekkesKemenkes, Surabaya

Jl. PucangJajarTimur No. 10, Surabaya, 60245, Indonesia

gebarends@gmail.com, bedjoutomo123@gmail.com, tribowo.tem81@gmail.com

Article Info

Article History:

Received Sep 9, 2019

Revised May 20, 2020

Accepted Jun 11, 2020

Keywords:

X-Ray; Geiger Muller;
Arduino Uno, Android;

Abstract

Radiation monitoring aims to know firsthand the rate of radiation exposure in a work area to ensure the safety and health of workers who will work in the radiation emitting area in accordance with the principle of ALARA (As Low As Reasonably Achievable). This study developed a nature X-ray radiation measuring device using a Geiger Muller tube detector and can display the results of the measurement of numbers in microSievert units and Counter Per Minute to the LCD Character display and Android which have function to reduce the radiation exposure received by the radiation workers. The output of the detector is processed using Arduino Uno. Comparison of the results of the module with a calibrated standard survey meter measures the reference that the module can be used. The radiation detection system testing of this module is carried out to adjust the current condition of the Covid-19 pandemic, so that the module tests the background radiation (natural radiation). Based on module testing and experiments, it was obtained that data from 10 times data collection showed the accuracy value of the radiation measuring device using a Geiger Muller detector was 90.71% for the measurement of background radiation in a closed room. The Geiger Muller detector is not accurate for measuring small radiation exposures, the module can be used to measure background radiation and fluoroscopy X-ray radiation.

Corresponding Author:

triwiyanto123@gmail.com

Department of Electromedical Engineering

PoltekkesKemenkes, Surabaya

This work is an open access article and licensed under a Creative Commons Attribution-ShareAlike 4.0 International License ([CC BY-SA 4.0](https://creativecommons.org/licenses/by-sa/4.0/)).



I. INTRODUCTION

Radiation can be interpreted as energy that is radiated in the form of particles or waves. Radiation cannot be felt directly by the five human senses, so radiation monitoring is needed, one way to monitor radiation is to use a survey meter. Radiation monitoring aims to know firsthand the rate of radiation exposure in a work area to ensure the safety and health of workers who will work in the radiation emitting area in accordance with the ALARA principle (As Low As Reasonably Achievable) [1]. Another monitoring system that can be applied to monitor the condition of the work environment exposed to ionizing radiation is to see the effects of aberration or chromosome damage in living things [2]. The safety and security aspects of radioactive substances from the sender to the recipient are things that must be guaranteed so as not to endanger humans, because the radiation from radioactive substances cannot be felt directly by the human senses so that a detector is needed to monitor the rate of radiation exposure [3]. The danger of radiation in a certain amount can cause ionization of human body cells and can damage body cells. The nature and severity of the effects of this radiation depend on the dose received by the tissue cell. The unit dose size for humans is called Rem. The biological effects of

radiation can be classified into two types namely deterministic effects and genetic effects (Rasad, et al, 1999).

Each nuclear radiation measuring device consists of two parts, namely the detector and supporting equipment. Radiation measuring devices commonly used are survey meters with several types such as ionization chamber detectors, Geiger Muller detectors, and proportional detectors, all of which are used for measurements in the radiation area field, so they are designed to display fast data. Radiation detector is the most important part of the radiation measuring system that functions to convert the amount of radiation into electrical signals or pulses. Research in the field of radiation monitoring systems is pretty much done, both in the field of design and development of radiation monitoring systems (Adi Abhimanyu, 2014).

Radiation measuring devices use Geiger Muller detectors to measure Co-60 radioactive sources, with graphical displays on a PC through the Visual Basic 6.0 program, the output results are in units of mR / Jam and $\mu\text{Sv} / \text{Jam}$, made by Djiwo Harsono, et al., In 2011, the title of the research is "Design of Wireless Radiation Monitor System". The advantage of this research is that sending data using RS232 can be sent from a distance of 500 meters in an open space and 200 meters in a closed room, the drawback is that the data transmission is still in the form of

analog data. Then in 2013, a radiation measuring device with a radiation monitoring system through the Hexapod robot which also had a camera, using a Geiger Muller detector, based on the ATmega16 microcontroller, displayed on a PC through Delphi programming, the output results were in units of mR / Jam, made by Joko Sunardi, et al. with the research title "Design and Build Data Acquisition Systems for Searching for Nuclear Radiation Sources Using Hexapod Robot" which is used to search for Co-60 radioactive sources. The strength of this research is that sending data using UM96 can transmit data from a distance of 220 meters in open space, the disadvantage is that data transmission is still in the form of analog data and the use of Hexapod Robot is not suitable for radiation monitoring in radiology rooms.

In the study "Testing of Radiation Monitor Modules in the Monitoring System for Transporting Radioactive Substances", a device made by Adi Abimanyu in 2014, the study used a Geiger Muller detector to monitor sources of Beta Cs-137 and Sr-90 radiation. In this tool based on the ATmega8 microcontroller, 2x16 LCD characters are displayed, the output is in mR / hr. The strengths of this research are the data processing using a microcontroller with IC AT89S52 which is affordable and the use of GSM / GPRS modules for sending data that facilitates monitoring and knowing the geographical location of radioactive substances, the use of Geiger Muller detectors produces accurate outputs and functions well proven by the testing method Chi Square Test, the drawback is not explained the use of GSM / GPRS modules in radiation monitoring in the radiology room. This Article is composed of:

In 2014, M. A. A. Mashud, et al. with the research title "A First Response Microcontroller Based Digital Radiation Survey Meter Using Scintillation Detector", using the NA (TI) Scintillation detector to monitor Gamma radiation. The tool is based on a PIC16F876 IC microcontroller programmed using C Language, using an LCD viewer, with output results in $\mu\text{Sv} / \text{Hour}$ units. The advantage of this research is data processing using a microcontroller with a PIC18F876 IC which is affordable, the Scintillation detector produces accurate and functioning outputs proven by comparing with the Canberra Nim Counter in SSDL, the drawback is the Scintillation detector requires a lot of amplifier circuits and the whole circuit requires cost expensive (it costs up to $\pm \$ 1000$). Then in 2015, Abdul Anriail, et al. make an X-ray radiation measuring device using a Scintillation detector, based on an ATmega16 microcontroller, there is an alarm indicator and an LCD display, the output results are in $\mu\text{Sv} / \text{Hour}$ units. In the study "Design of Radiation Monitoring Tool in Radiodiagnostic Room Based on ATmega 16 Microcontroller" has the advantage that the use of a Scintillation detector produces an output that has a 95% accuracy rate proven by the t-test method and compared with a standard Surveymeter.

Radiation measuring instrument with a radiation source monitoring system Beta Cs-137 and Sr-90 using a Geiger Muller detector, based on an Arduino microcontroller, using a 128x64 pixel LCD graphic viewer, with output in units of $\mu\text{Sv} / \text{Hour}$, has been made by Nur Aira Abd Rahman, et al., in 2016, with the research title "Arduino Based Radiation Survey Meter". The strengths of this research are the use of Geiger Muller detector

LND7121 type produces an accurate output compared to CF Surveymeter, the drawbacks are significant dead time on measurements $> 3500 \mu\text{Sv} / \text{h}$ and the use of excessive graphic LCD if only to display numerical outputs. Then in 2017, Nur Aira Abd Rahman, et al. continued the research in the "GSM Module For Wireless Radiation Monitoring System Via SMS" research but did not explain the type of radiation measured. This tool uses a Geiger Muller detector, based on an ATmega 328p microcontroller, using a 128x64 pixels LCD graphical display and SMS, the output results are in units of $\mu\text{Sv} / \text{Hour}$. The advantages of this study are that data can be received for emergencies outdoors, the drawback is that it consumes a lot of battery consumption (batteries run out quickly), excessive use of LCD graphics if only to display output numbers and sending data via SMS is difficult to be received because it is difficult to detect signals GSM / GPRS in the radiology room.

From some of the research that has been done it can be concluded that the use of Arduino microcontroller is more practical, inexpensive, and easier than other microcontrollers, sending data using Bluetooth is more suitable for measurements in the radiology room, sending data using GSM / GPRS is more suitable for sending data in outside the radiology room, Geiger Muller detectors do not require much cost and many amplifier circuits compared to other detectors (such as Scintillation detectors) because the output voltage is high (in volts) and research has never been done using Geiger Muller detectors for X-ray radiation measurements. For the purposes of displaying the results of data measurements in numerical form, it is sufficient to use the character LCD.

In this tool will be given some technological innovations from radiation measuring devices in general, namely by using a Geiger Muller tube detector and can display the results of the measurement of numbers in microSievert units or milliRoentgen on LCDs and Android smartphones that utilize Bluetooth menus and applications that are easily downloaded on Android smartphones. With this innovation it is expected to facilitate the use and safety of users of radiation measuring devices in measuring and reading ionizing radiation such as X-ray radiation. The use of Arduino Uno Microcontroller and Bluetooth module is the result of the development of practical technology (hardware and software) at a fairly affordable price. From the above background, a thesis will be discussed and compiled under the heading "Arduino-Based X-ray Radiation Measurement Appears Android"

Chapter 1 introduction, Chapter 2 Material and Methods, Chapter 3 Result, Chapter 4 Discussion, Chapter 5 Conclusion, and Chapter 6 Reference.

II. MATERIALS AND METHODS

A. Experimental Setup

This research uses two measurement points of nature radiation, that is indoors and outdoors. module at the testing house (Karang Menjangan) with the method of taking data as much as 10 times the data arising from background radiation at one point in the room

B. Materials and Device

The tools used in this study consist of Toolset, Avo meter, smartphone, Oscilloscope. The material used in this study consisted of Arduino Uno, LCD and LCD Module 2x16, Bluetooth Module, Geiger Muller Detector Tube CTC-05, and several Electronic Circuits Measuring instrument using a multimeter digital.

C. Experiment

In this study, radiation detection system testing of this module is done to adjust the conditions that are happening, so that the module is tested against background radiation (nature radiation) that is indoors and outdoors. Based on the testing of the radiation detection system module at the testing house (Karang Menjangan) with the method of taking data as much as 10 times the data arising from background radiation at one point in the room.

D. The Diagram Block

In (Fig. 1) show Oscillator circuit, Bluetooth module, and LCD get voltage input from the battery module. The output of the oscillator circuit will be input to the next circuit which is entered into the high voltage Step Up DC circuit. This Step Up DC circuit serves to increase the voltage so as to produce a high voltage output which is then used as the working voltage of the Geiger Muller detector. The existence of a potential difference in the anode and cathode detector of Geiger Muller gives rise to an electric field so that the pair of electron ions get a large enough addition of kinetic energy, then there is an event of separation of negative ions and positive ions. When the detector detects the charged radiation entering through the tube window, the electrons will move toward the detector cathode to produce current, the frequency counter voltage is proportional to the intensity of the radiation received. The output voltage of the detector is then entered and processed by the microcontroller.

The results of the enumeration are then processed by converting each voltage counter then multiplied by one minute, resulting in the number of counters counted in one minute or called CPM (Count per Minute). The CPM is then converted to the μSv (MikroSievert) value unit by multiplying the results of the CPM with the conversion factor of the type of tube used to produce output in units of mR (milliRontgen). The results of the microcontroller data processing are then displayed to the 2x16 LCD and sent via a Bluetooth module which is then displayed on an Android smartphone.

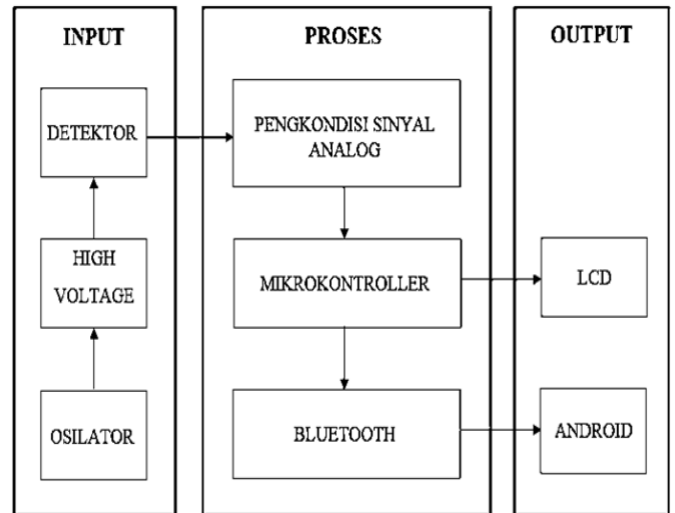

Fig 1. The diagram block

E. The Flowchart

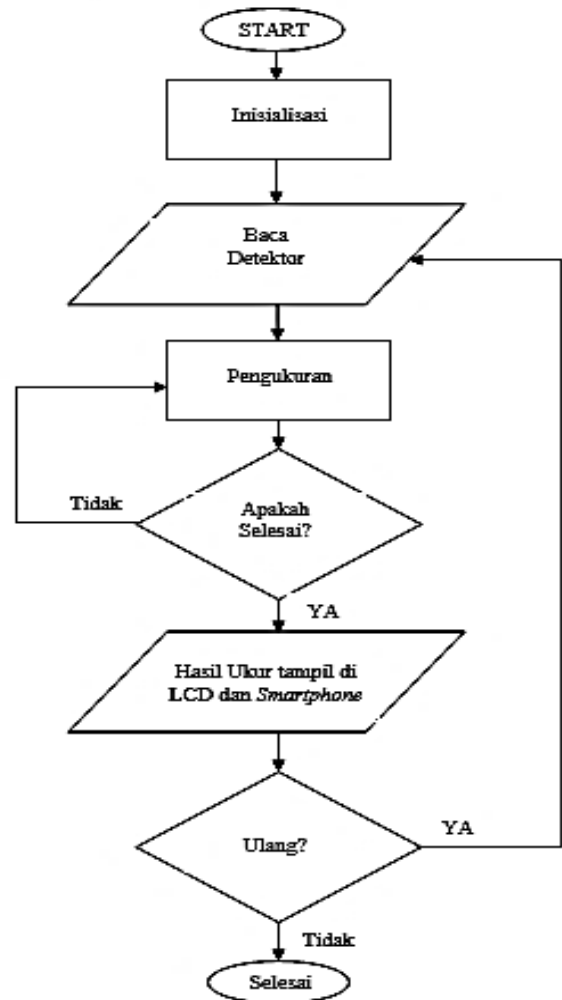

Fig 2. The Flowchart

The work flow of the flow chart is when the device is turned on, the detector works. Then when the detector works, the detector can detect the radiation received by the detector, then the measurement of the received radiation runs which then produces a voltage. There are buzzer and LED indicators as indicators of the detection of radiation by the detector. Measurement of voltage counts starts, which is then converted to Arduino, data from the Arduino is displayed on the LCD and also on the Smartphone. Press the reset button to repeat the enumeration. Press the power ON / OFF button to stop the operation of the appliance.

F. Circuit

1) Switch Circuit

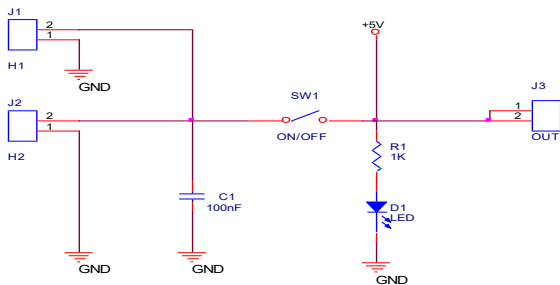

Fig 3. ON / OFF Switch Circuit

In (Fig. 3), this circuit serves as the main supply path to the next circuit by using LED lights as a positive voltage indicator flowing at the output.

2) Frequency Generator Circuit

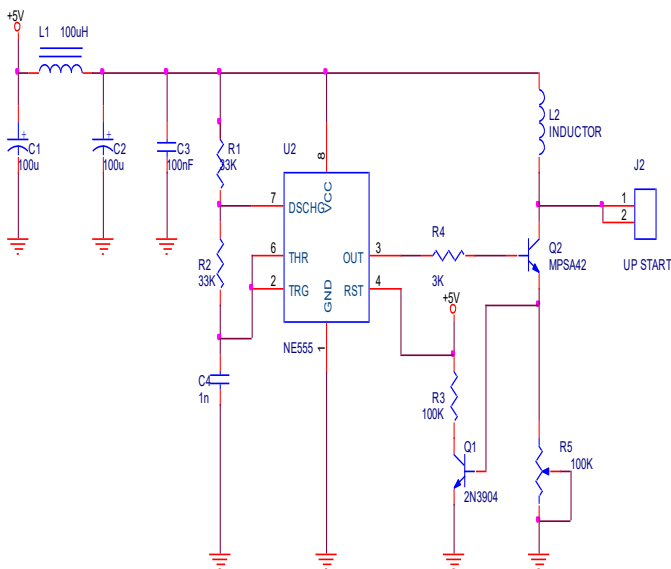

Fig 4. Frequency Generator Circuit

In (Fig. 4), this circuit using NE555 IC as a frequency generator, inductor components are used to amplify currents and multiterm resistor components are used to help regulate the currents that affect the circuit output.

3) Voltage Generator Circuit

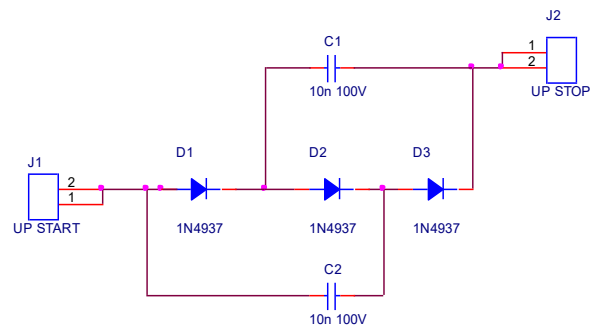

Fig 5. Voltage Generator Circuit

In (Fig. 5), As per the specifications of the 1N4937 rectifier diode it can generate voltages up to 600Volt DC. The voltage from the frequency generator circuit enters this circuit in the Up Start connector which is then generated by diode 1N4937 and stabilized with a capacitor.

4) Detector Circuit

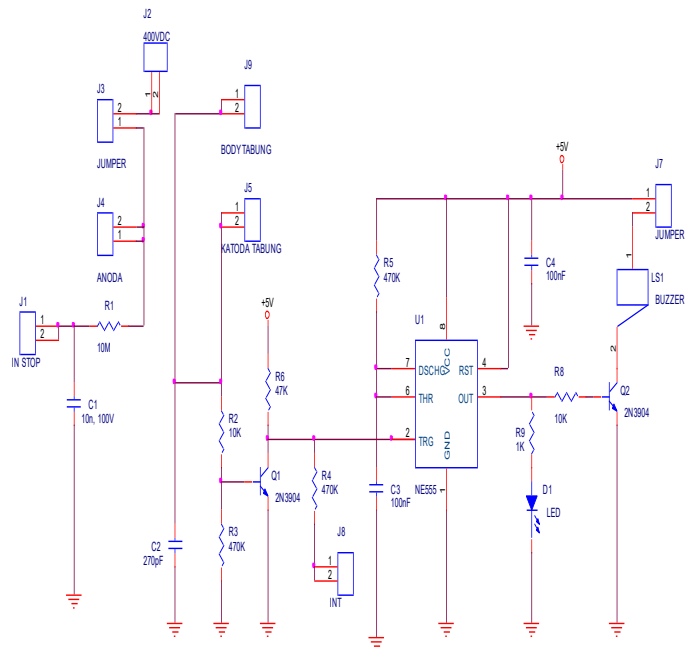

Fig 6. Detector Circuit

In (Fig. 6), high voltage enters the IN Stop connector, then at the input there is a safety resistor with a minimum value of R 5k Ohm according to the Geiger Muller CTC-05 Anode specification. When X-ray radiation is received by a Geiger Muller detector, the high voltage from the anode flows to the detector cathode. The voltage from the Cathode detector enters the Astabil circuit with the NE555 IC, the output of the NE555 IC flows to the LED and Buzzer. So that the LED and Buzzer light up as an indicator of the radiation received by the Geiger Muller detector.

5) Conditioning Signal Circuit

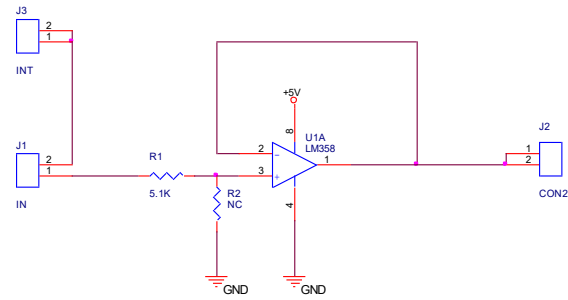

Fig 7. Conditioning Signal Circuit

In (Fig. 7), this analog signal conditioning circuit gets input from the Cathode INT output point of the detector circuit. The signal conditioning circuit is used to condition the signal from the detector cathode so that the output voltage of the detector cathode can be read on Arduino.

III. RESULTS

A. Circuits Result

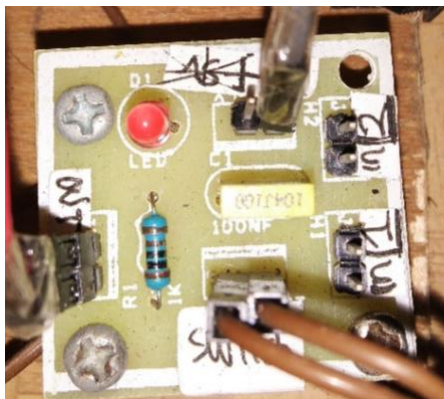

Fig 8. ON / OFF Switch Circuit

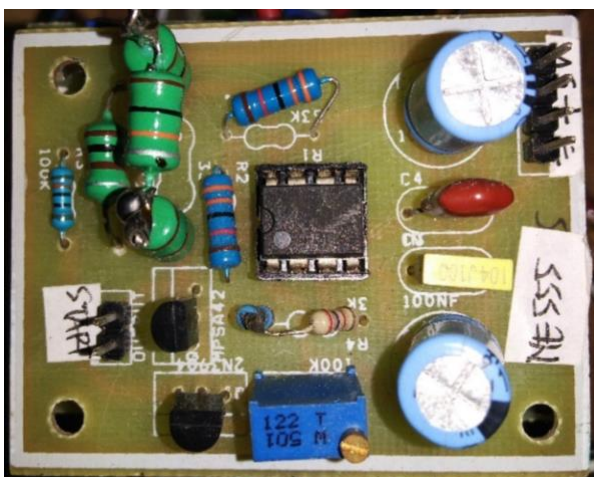

Fig 9. Frequency Generator Circuit

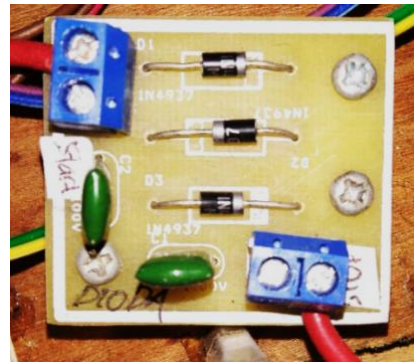

Fig 10. Voltage Generator Circuit



Fig 11. Detector Circuit

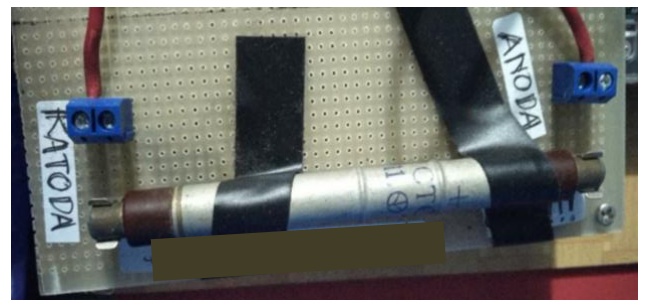

Fig 12. Detector Geiger Muller CTC-05

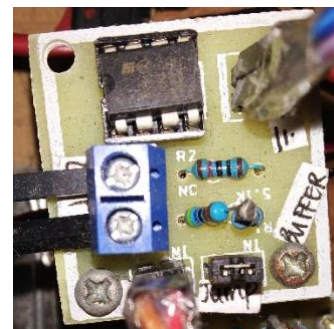

Fig 13. Conditioning Signal Circuit

In (Fig. 8), there is a circuit switch Power ON / OFF using the SPST switch and supply + 5V and GND. The output of the switch circuit goes to the frequency generator circuit. In (Fig. 9) there is a Frequency generator circuit that uses IC NE555 as the main component of a frequency generator, also using an inductor to amplify the output current. Then in (Fig. 10) there is a DC high voltage generator circuit that uses diode rectifier 1N4937 as the main component of voltage generator also uses a capacitor to stabilize the output voltage.

In (Fig. 11, 12), there is a series of detectors using Geiger Muller CTC-05 detectors and using IC NE555 which helps show indicators of the output of the detector cathode. Then in (Fig. 13) there is a Signal Conditioning circuit, this circuit uses supply + 5V and GND to supply IC LM358.

B. Listing program for Library Input and Initialization

```
#include <SPI.h>
#include <LiquidCrystal_I2C.h>
LiquidCrystal_I2C lcd(0x27,16,2);
//inisialisasi LCD Karakter 2x16

#define LOG_PERIOD 15000
//periode logging dengan nilai antara 15000-60000

#define MAX_PERIOD 60000
//Nilai maksimal periode logging

#define CONV_FACTOR 0.00812
//faktor konversi tiap 1 periode

unsigned long counts; //variable untuk detektor GM
unsigned long cpm; //variable untuk CPM
unsigned int multiplier; //variable untuk mengkalkulasikan CPM
unsigned long previousMillis; //variable waktu pengukuran

int geiger_input = 2;
unsigned long count = 0;
unsigned long countPerMinute = 0;
unsigned long timePrevious = 0;
unsigned long timePreviousMeasure = 0;
unsigned long time = 0;
unsigned long countPrevious = 0;

float radiationValue = 0;
float milliRontgen = 0;
```

The above program is a library for LCDs and also a library for converting counts of output voltage periods from Geiger Muller detectors to Arduino. In the program listing there are variable variables used such as Long Counts variable for counter detector output voltage counters, cpm variable for counters per minute, variable multiplier for multiplying count conversion.

C. Listing program for Running Command

```
void tube_impulse()
{
  counts++;
}

void setup()
{ //setup subprocedure

  lcd.init();
  // inisialisasi lcd

  lcd.backlight();
  counts = 0;
  cpm = 0;
  multiplier = MAX_PERIOD / LOG_PERIOD;

  Serial.begin(9600);

  attachInterrupt(0, tube_impulse, FALLING);

  lcd.begin(16, 2);
}
```

The above program is used for initial LCD initialization and for counting the output voltage from a Geiger Muller detector that enters Arduino. Counter and cpm values start at 0. The program starts counting counts (multipliers) when Arduino can detect the output voltage from the Geiger Muller detector tube. The *attachInterrupt* function is that Arduino immediately works to detect the voltage of the incoming Geiger Muller detector tube without having to wait for another logic.

D. Listing program for Display on the LCD

```
Serial.print("CPM = ");

Serial.print(countPerMinute, DEC);
Serial.print(" - ");
Serial.print("mSv/h = ");
Serial.print(milliRontgen,4);

lcd.clear();

lcd.setCursor(0,0);
lcd.print("CPM = ");

lcd.setCursor(6,0);
lcd.print(countPerMinute);
lcd.setCursor(0,1);

lcd.print(milliRontgen,4);
lcd.setCursor(8,1);
lcd.print("uSv/h");
```

```

count = 0;

delay(3000);
}
}
    
```

In the above program, it is used to start converting the voltage results that Arduino has received on pin 4 (*milliRontgen*), the results of the chopped input voltage are then converted into CPM units, displayed in line 1 (*lcd.setCursor (0,1)*), and also converted into uSv/h units shown in line 2 (*lcd.setCursor (0,2)*).

When the module is turned on, all circuit blocks will get a supply voltage. The anode detector gets a high voltage DC so it can work detecting radiation. When incoming radiation is received by a Geiger Muller detector, the high-frequency DC high voltage from the detector Anode can flow to the detector Cathode. The voltage from the Cathode detector enters the Astabil circuit with the NE555 IC, the output of the NE555 IC flows to the LED and Buzzer. So that the LED and Buzzer light up as an indicator of the radiation received by the Geiger Muller detector. Conditioning Circuits Analog signals which get input from the Cathode INT output point of the detector circuit. The signal conditioning circuit is used to condition the signal from the detector cathode so that the frequency output voltage of the detector cathode can be read on Arduino. Arduino reads the number of voltage counters that enter Arduino per milliseconds which is then converted to units of Counter Per Minute (CPM) and also units of microSievert per hour (uSv / h). The results of the data from the converted readings are displayed on the 2x16 character LCD.

E. The Average and Accuracy Voice Recognition value

TABLE I. AVERAGE MEASUREMENT MODUL

No	Pengukuran Pada Modul	
	Satuan CPM	Satuan uSv/h
1	23 CPM	0,131 uSv/h
2	28 CPM	0,159 uSv/h
3	31 CPM	0,176 uSv/h
4	24 CPM	0,136 uSv/h
5	29 CPM	0,165 uSv/h
6	27 CPM	0,153 uSv/h
7	25 CPM	0,142 uSv/h
8	24 CPM	0,136 uSv/h
9	28 CPM	0,159 uSv/h

10	32 CPM	0,182 uSv/h
Rata Rata	27,1 CPM	0,154 uSv/h

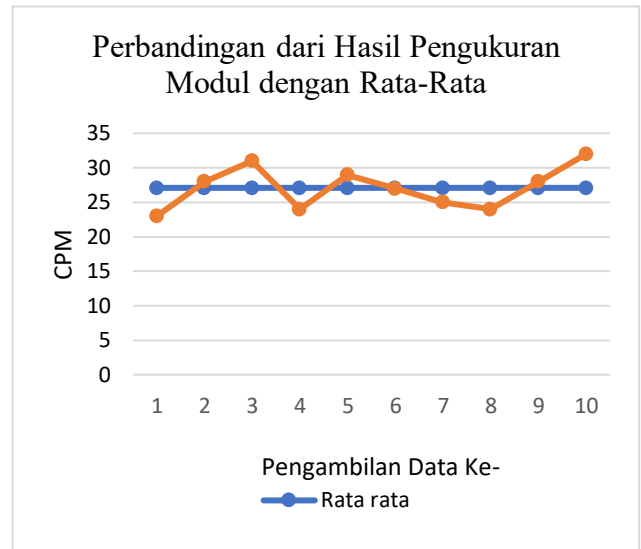

Fig 14. Graph Comparison of Background Radiation Measurement in the Room and the Average in CPM Units

Based on the results of data from measurements that have been made, the results of data analysis obtained from the average value, error value, percentage error and percentage accuracy of the module that has been made produce the table below, assuming that the average value of the measured output is a value definitely at that point that is at 1 point in the room

TABLE II. MEASUREMENT ANALYSIS OF BACKGROUND RADIATION MEASUREMENT IN THE ROOM AND THE AVERAGE IN CPM UNITS

No	Hasil Modul (CPM)	Nilai Rata Rata	Nilai Error	Persentase Error (%)	Persentase Akurasi (%)
1	23	27,1	4,1	15,12	84,88
2	28	27,1	0,9	3,32	96,68
3	31	27,1	3,9	14,39	85,61
4	24	27,1	3,1	11,43	88,57
5	29	27,1	1,9	7,01	92,99
6	27	27,1	0,1	0,36	99,64
7	25	27,1	2,1	7,74	92,26
8	24	27,1	3,1	11,43	88,57
9	28	27,1	1,1	4,05	95,95
10	32	27,1	4,9	18,08	81,92

TABLE III. AVERAGE MEASUREMENT AND ACCURACY OF BACKGROUND RADIATION MEASUREMENT IN THE ROOM

Nilai Rata- Rata dari 10 Data			
Hasil Modul (CPM)	Error	Persentase Error (%)	Persentase Akurasi (%)
27,1 CPM	2,52	9,29	90,71

In this study, radiation detection system testing of this module is done to adjust the conditions that are happening, so that the module is tested against background radiation (nature radiation) that is indoors and outdoors. Based on the testing of the radiation detection system module at the testing house (Karang Menjangan) with the method of taking data as much as 10 times the data arising from background radiation at one point in the room.

Table 1, Table 2, and Table 3 show that the measurement results of this module have an average value of 27.1 CPM with an error percentage value of 9.29%, and an accuracy percentage of 90.71%. This is caused by many environmental factors that affect the amount background radiation (natural radiation), such as environmental conditions, the number of living things that have different radiation.

IV. DISCUSSION

Based on the results of data from measurements that have been made, the results of data analysis obtained from the average value, error value, percentage error and percentage accuracy of the module that has been made produce the table below, assuming that the average value of the measured output is a value definitely at that point that is at 1 point in the room. Shown in Table 1 and Table 2 with data collection 10 times which shows the accuracy of the radiation measuring instrument using a Geiger Muller detector is 90.71% for radiation measurements in a closed room. The development of this research can be done on the use of a more stable high voltage circuit that can improve the final results of radiation measurements, add programs to record and store measurement results that can be used for calibration and exposure testing.

V. CONCLUSION

The purpose of this study is the module can be concluded that an "Arduino-based X-ray Radiation Measurement Appearance can be made Android" using a Geiger Muller detector component, a high frequency generator and a DC high voltage generator circuit can be made, based on the results of data from measurements has been done, the results of data analysis obtained from the average value, error value, error percentage and percentage accuracy of the modules that have been made produce the table below, assuming that the average value of measured output is a fixed value at that point, namely at 1 point in the room. Shown in table 1 and table 2 with data collection 10 times which shows the accuracy value of the radiation measuring instrument using a Geiger Muller detector is 90.71% for radiation measurements in a closed room, Geiger Muller Detector is not accurate for measuring small radiation exposure, Arduino programming software can be made to

measure the radiation exposure that is converted in a unit of Counter Per Minute and microSievert per Hour, based on module testing and experiments it is found that the module can be used to measure background radiation and X-ray fluoroscopy.

REFERENCES

- [1] Nur Insan, Wira Bahari Nudin, Bualkar Abdullah. *Pengaruh Variabel Jarak Terhadap Faktor Kalibrasi Pada Peralatan Surveymeter*, 2016
- [2] A.,Zubaidah, Lusiyanti, Y., P., Sofiati, Ramadhani,D., L., Masnelly, dan A.S., Viria. 2012. Respon Sitogenetik Penduduk Daerah Radiasi Alam Tinggi di Kabupaten Mamuju Sulawesi Barat.Jurnal Sains dan Teknologi Indonesia, Vol. 13 No.1 February 2012
- [3] Adi Abimanyu. *Pengujian Modul Monitor Radiasi Pada Sistem Pemantauan Pengangkutan Zat Radioaktif*. Jnteti, Vol 3. Mei, 2014.
- [4] Nur Aira Abd Rahman, , Noor Hisyam Ibrahim, Lojius Lombigit, Azraf Azman, Zainudin Jaafar, Nor Arymaswati Abdullah, Glam Hadzir Patai Mohamad. *Gsm Module For Wireless Radiation Monitoring System Via Sms*. 2017.
- [5] Nur Aira Abd Rahman, Lojius Lombigit, Nor Arymaswati Abdullah, Azraf Azman, Taufik Dolah, Amir Muzakkir, Zainudin Jaafar, Glam Hadzir Patai Mohamad, Abd Aziz Mhd Ramli, Rasif Mohd Zain, Fazila Said, Mohd Ashhar Khalid, And Muhamad Zahidee Taat. *Arduino Based Radiation Survey Meter*. 2016
- [6] Abdul Anrifail, Bidayatul Armynah, Bualkar Abdullah.*Rancang Bangun Alat Monitoring Radiasi Pada Ruang Radiodiagnostic Berbasis Mikrokontroler Atmega 16*. 2015
- [7] M.A.A. Mashud, S.M.S. Hossain, M.A. Razzaque, M.S. Islam. *Pengujian Modul Monitor Radiasi Pada Sistem Pemantauan Pengangkutan Zat Radioaktif*. Oktober, 2014.
- [8] Joko Sunardi, Djiwo Harsono, Alan Batara Alauddin. *Rancang Bangun Sistem Akuisisi Data Untuk Pencarian Sumber Radiasi Nuklir Menggunakan Robot Hexapod*. November, 2013.
- [9] Djiwo Harsono, Joko Sunardi, Suliswanto. *Rancang Bangun Sistem Monitor Radiasi Nirkabel*. November, 2011.
- [10] F. Shoufika Hilyana. *Penentuan Tegangan Operasional Pada Detektor Geiger Muller Dengan Perbedaan Jari-Jari Window Detektor*. April, 2017.
- [11] Kristiyanti, Irianto, Sumarmo. *Redesain Sistem Pengisian Detektor Geiger-Muller Dengan Isian Gas Tekanan Rendah*. November, 2011.
- [12] W Singseeta, D Thong-Aram, S Pencharee. *Design And Construction Of Portable Survey Meter*. 2017.
- [13] IAEA. *Eadiation Protection And Safety Of Radiation Sources: International Basic Safety Standards*. General Safety Requirements Bagian 3. No. Gsr Bagian 3. July, 2014
- [14] Jorena Bangun, Hadir Kaban. *Pengukuran Efisiensi Tabung Geiger Muller Counter Cacahan B Dan B/T*. 49-60. April, 1999.
- [15] Azam, M., Hilyana, F. S., Setiawati, E. *Penentuan Efisiensi Beta Terhadap Gamma Pada Detektor Geiger Muller*, 73-77. 2007
- [16] G. Rajan, J. Izewska. *Medical Physics And Safety Section*. Mumbai, India.
- [17] Akhadi, Mukhlis. *Dasar-Dasar Proteksi Radiasi*, Jakarta, Indonesia, Rieneka Cipta,2000.
- [18] James A. Turner. *Atoms, Radiation And Radiation Protection* Edisi Ketiga, Dilengkapi, Direvisi Dan Diperluas. Weinheim, Germany, Wiley-Vch Verlag Gmbh & Co. Kгаа, 2007
- [19] James E. Martin. *Physics For Radiation Protection*, Edisi Ketiga. Weinheim, Germany, Wiley-Vch Verlag Gmbh & Co. Kгаа, 2013.
- [20] Gautreau, Ronald, William Savin. *Seri Buku Schaum: Teori Dan Soal-Soal Fisika Modern*. Jakarta, Erlangga. 1995.
- [21] BATAN. *Standar Batan: Proteksi Dan Keselamatan Radiasi Batan*. 2014
- [22] BAPETEN. *Peraturan Kepala Badan Pengawas Tenaga Nuklir Nomor 4 Tahun 2013 Tentang Proteksi Dan Keselamatan Radiasi Dalam Pemanfaatan Tenaga Nuklir*. 2013