

Manuscript received October 14, 2021; revised October 24, 2021; November 6, 2021; date of publication November 7, 2021

Digital Object Identifier (DOI): <https://doi.org/10.35882/ijeemi.v3i4.5>

This work is an open-access article and licensed under a Creative Commons Attribution-ShareAlike 4.0 International License ([CC BY-SA 4.0](https://creativecommons.org/licenses/by-sa/4.0/))



# The Elderly Alzheimer Patient's Portable Tools for Position Detection with SMS Notifications

Yulastri, Era Madona, Anggara Nasution and M.Irmansyah

Electrical Engineering Department, Politeknik Negeri Padang, 25168, Padang – Sumatera Barat, Indonesia

Corresponding author: [yulastripnp70@gmail.com](mailto:yulastripnp70@gmail.com)

**ABSTRACT** In this study, we propose a portable tool to monitor and monitor patients at risk of Alzheimer's. The aim of this research was to design and make a useful tool to determine the position and condition of Alzheimer's sufferers. The research stages consisted of designing hardware, software and testing the whole tool. The patient's condition find out by an accelerometer sensor was used which read the values of the x, y, and z axes to determine the condition of the patient normal or falling. This tool also has a panic button which is used by the patient if he does not know his position and forget the way to go home, and SMS notification will be sent to the colleague when this button is pressed. The results of the test show the device can send an SMS notification of the patient's position when the supervisor sends an SMS "GPS ON," and the navigation module can determine the location of the position. The distance between the reading position of the GPS module to the test point on average was 2.39 meters. Generally speaking, the tool can be working properly.

**INDEX TERMS** Alzheimer's patient, Microcontroller, GPS, MPU6050, SMS

## I. INTRODUCTION

Alzheimer's disease was a progressive degenerative disease of the brain that commonly affects older people. This disease is characterized by confusion, disorientation, memory failure, speech problems, and dementia. The risk of developing Alzheimer's increases with age [1][2]. Approximately 47 million people suffer from Alzheimer's disease in the world [3], and as many as 27 million of them are in Asia [4] Indonesia based on the results of the 2014 National Economic Survey, the number of elderly people in Indonesia reached 20.24 million people or about 8.03% of the entire population of Indonesia. This data shows an increase when compared to the results of the 2010 Population Census, namely 18.1 million people or 7.6% of the total population. Alzheimer's disease is most commonly seen in older people > 65 years of age, but it can also affect people around 40 years of age [5]. Alzheimer's disease can make the elderly get lost when walking out and forget the way home [6]. Lack of information and time to report to the police as well as inadequate CCTV face identification tools because they only applied to certain areas a problem in monitoring Alzheimer's patients. Based on data from the Radio Suara Surabaya Research Team, from January 2017 to July 2019, Radio

Suara Surabaya has received 618 listener reports about missing people due to dementia or senility. Due to this, action is needed in the form of surveillance for someone who experiences symptoms of Alzheimer's [8].

The development of information technology has given birth to technological innovations in the health sector, including research [9][10][11]. Mobile application-based surveillance of patients with disease-at-risk has been developed for diabetes[12][13][14], cardiac[15][16] and stroke [17][18][19] patients. In addition, microcontroller-based patient monitoring with notification has also been carried out for premature infants [20] and the risk of prolonged sitting [21]. In this study, we made a small, low-cost, portable device to monitor and monitor patients with Alzheimer's symptoms. Several related studies have been carried out before a study conducted used Arduino, gyroscope, and accelerometer sensors to measure the falling motion of the elderly. The results showed the system could detect and distinguish between conscious and accidental falls. Using the MPU6050 sensor with a 3-axis accelerometer and a 3-axis gyroscope [22] conducted a study to detect elderly activities with the backpropagation method used for motion recognition. The results showed an accuracy rate of 0.1818 with a ROC of 98.12%. A similar study was also conducted

by [16] using the line application as LINE BOT if the elderly were detected falling. The results showed the system could send alarms with high effectiveness.

The development of the previous research is (1) Notifications are cheaper because they use SMS compared to the internet network, (2) Monitoring can be done in two directions where the family can find out the patient's position by sending an SMS to the device used by the patient.

The approach to making this tool uses a wearable sensor-based [17]. Wearable sensor-based, used for device cost efficiency, installation, and arrangement of the design is also not complicated. Therefore, the device is relatively easy to operate [18]. With this tool, the supervisor can find out the position of the patient by sending an SMS to the device attached to the patient in a certain format. This tool is also equipped with a panic button if the patient does not know its position and forgets to go home. In addition, this tool also uses an accelerometer sensor which is a protection for Alzheimer's patients when the majority of patients are elderly when they go out and fall. The sensor will detect the tilt of the patient, the majority of whom are elderly people, fall left, right, backward, forward, and send notifications. SMS to supervisor for the coordination of the patient's position. The aim of this research was to design and build a useful tool to determine the position and condition of Alzheimer's patients. This tool can be used to monitor and track Alzheimer's patients to stay healthy and protect them in their activities.

**II. MATERIALS AND METHODS**

The method used in this research was making prototype tools starting from literature study, system design, hardware design (hardware), software design (software), hardware testing, software, and analysis of test results. The stages of research on The portable tools of the elderly Alzheimer's patient can be seen in **FIGURE 1**.

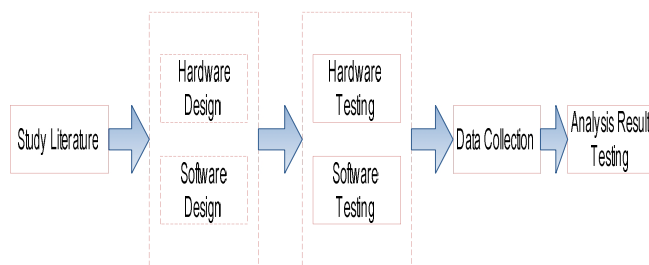
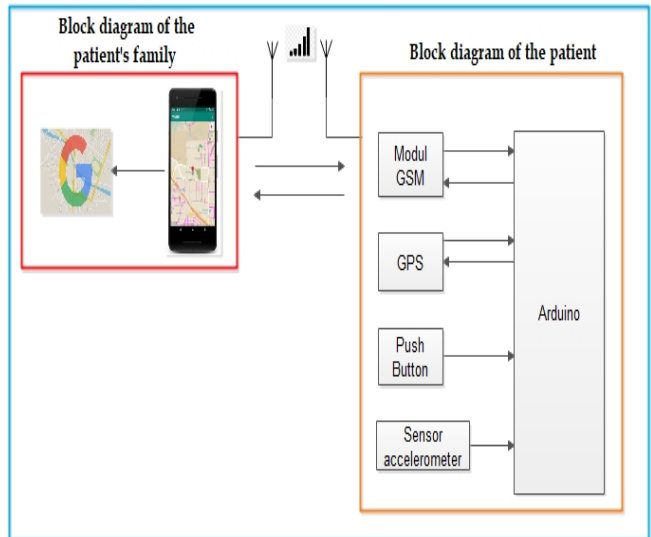

**FIGURE 1. Research methods**

**A. THE DIAGRAM BLOCK**

The method used in this research is making prototype tools starting from literature study, system design, hardware design, software design, hardware testing, software, and analysis of test results. This tool for monitoring the position of Alzheimer's patients is used for elderly patients who are placed on their waist; when Alzheimer's patients leave the house for a long time and forget to go home, the supervisor

wants to know their location, so orders are carried out by the user or supervisor with a specific command format sent to SIM800L. Then the message on the SIM800L will be processed by Arduino nano. The working principle of the tool can be seen in **FIGURE 2**.



**FIGURE 2. System Block Diagram.**

Location data sent by GPS U-Blox Neo coordinates the location of the patient's whereabouts. This data will be processed by Arduino nano which will later be sent to SIM800L. SIM800L will forward the contents of the message in the form of the location coordinates of the whereabouts to the supervisor's cellphone. This coordinate point is opened in the Google Maps application, wherefrom the message. There is a web URL address. In the Google Maps application, the patient's location can be seen in the form of a digital map. The push-button functions as a panic button if the patient does not know his position and forgets to go home, Arduino will process it, and GPS U-Blox Neo will send coordinate location data to SIM800L and then forward by SIM800L to the patient supervisor's cellphone. The accelerometer/tilt sensor functions to detect the slope of the patient, the majority of whom are elderly people who fall, whether they fall left, right, backward, or forward. Arduino will process it, then it will be forwarded to GPS U-Blox Neo and will send coordinate location data to SIM800L and then forwarded by SIM800L to the patient monitoring cellphone.

**B. HARDWARE DESIGN**

This circuit consists of an Arduino nano functioning as a microcontroller, a GSM SIM800L module, a GPS module, a push button, a tilt angle detector using the MPU6050 accelerometer. The battery is connected to the 5V and GND pins, as seen in **FIGURE 2**. The MPU6050 sensor has 2 (two) pins that will be connected to the Arduino pin, namely pin A5 (SCL), pin A4 (SDA) on the microcontroller detecting the tilt of the patient's position, which is placed on the prototype bag when experiencing a change in position

which is divided into several conditions. To determine the patient's condition on the accelerometer sensor can be seen in table 1. The battery as a mobile voltage source for this system is connected to the +5V and GND microcontroller and +4V to the SIM800L GSM module. In order to get a voltage of +4VDC, a DC-DC converter is needed. The RXD pin on the SIM is connected to pin seven on the Arduino, and the TXD pin is connected to pin 7 of the Arduino, such as in **FIGURE 3**.

**FIGURE 3.** Electronic circuit of The portable tools of the elderly alzheimer patient

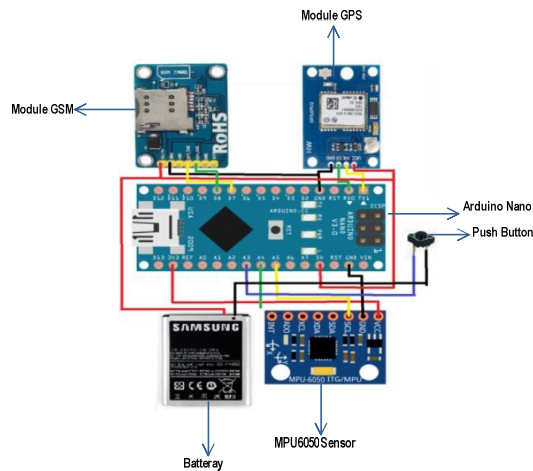

The series of GPS modules is connected to the 3.3V pin on the Arduino as a voltage input. The GPS is connected to the GND pin on the Arduino for grounding. The GPS module has 2 (two) pins that will be connected to the Arduino pin, namely, pin 0 (TXD) and pin 1 (RXD). The push-button input circuit as a panic button is connected to the 5V pin on Arduino as a voltage input. Meanwhile, the output is connected to pin 2. The device is made to be placed on the patient's belt. The design of the toolbox can be seen in **FIGURE 4**.



**FIGURE 4.** Tool Prototype Design of The portable tools of the elderly Alzheimer's patient

**C. SOFTWARE DESIGN**

The flowchart for monitoring Alzheimer's patients with SMS notifications can be seen in **FIGURE 5**. The process starts with the initialization of I/O. Furthermore, there are three stages of checking; first, the incoming SMS is in the SMS format "ON," the second is the panic button with a value of "1," and the Accelerometer sensor reading. The device will read the patient's location and send an SMS notification of the patient's location to the supervisor's cellphone. Programming in this study uses Arduino IDE.

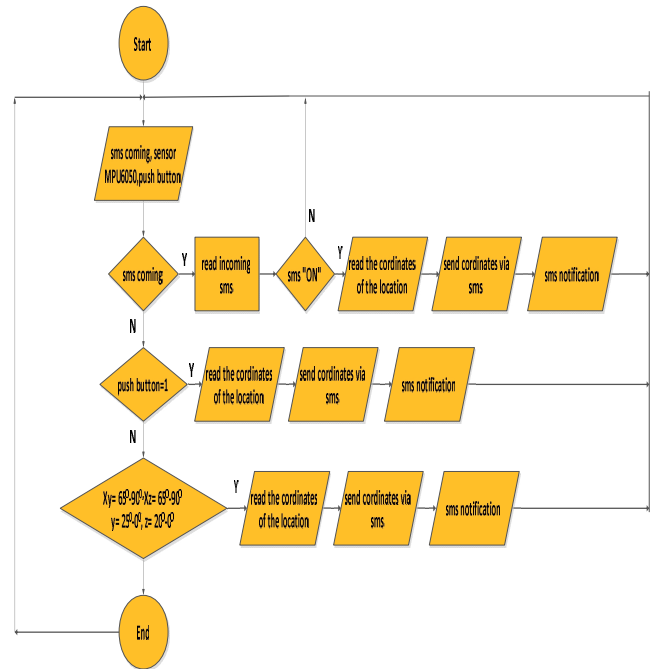

**FIGURE 5.** Flowchart of The portable tools of the elderly Alzheimer's patient

**D. PROGRAMMING SYSTEM**

Programming in this study used Arduino IDE version 1.8.14 for Arduino nano. The overall system flowchart can be seen in **FIGURE 5**. Programming stages start from data acquisition and control, as shown in listing program 1.

**Listing program 1.** Program Arduino Nano for sensor data acquisition and control.

```
#include <Adafruit MPU6050.h>
#include <Adafruit_Sensor.h>

mpu.setGyroRange(MPU6050_RANGE_500_DEG);
Serial.print("Gyro range set to: ");
switch (mpu.getGyroRange()) {
case MPU6050_RANGE_250_DEG:
Serial.println("+ - 250 deg/s");
break;
case MPU6050_RANGE_500_DEG:
Serial.println("+ - 500 deg/s");
break;
case MPU6050_RANGE_1000_DEG:
Serial.println("+ - 1000 deg/s");
break;
case MPU6050_RANGE_2000_DEG:
```

```

}
Serial.println("+ 2000 deg/s");
break;

```

followed by programming of SMS notifications and GPS locations as shown in program listing 2.

#### Listing program 2. SMS Notification and GPS Location

```

#include <Wire.h>
#include <TinyGPS++.h>
#include <SoftwareSerial.h>
SoftwareSerial SIM800L(7, 8);

a. SMS Notification

if (SIM800L.available()>0){
response = SIM800L.readStringUntil('\n');
}
if(lastStringLength != response.length())
{
if(response.indexOf("ON") == 4)
{
digitalWrite (13,LOW);
delay (500);
digitalWrite (13,HIGH);

if ((a.acceleration.x < 5)){ /*|(a.acceleration.x < 1)*/
SIM800L.println("AT+CMGF=1");
delay(1000); // Delay of 1000 milli seconds or 1 second
SIM800L.println("AT+CMGF=1");
delay(1000);
SIM800L.println("AT+CMGS=\\"085263598xxxx\\"r");
delay(1000);
}

b. GPS Location

if(Serial.available() {
}
gps.encode(Serial.read());
if(gps.location.isUpdated() {
latitude = gps.location.lat();
longitude = gps.location.lng();
link = "www.google.com/maps/place/" + String(latitude, 6) + "," +
String(longitude, 6) ;
//link = "www.google.com/maps/place/" + String(latitude, 6) + "," +
String(longitude,
6) ;
}
Serial.println(link)

```

### III. RESULT

Furthermore, testing the tool aims to determine the advantages and disadvantages of the system that has been made. The test is carried out in two stages. The test consisted of testing the MPU6050 sensor, module GSM SIM800L, and U-BLOX NEO GPS module. The tool in the form of a prototype bag is then installed on the patient, as seen in **FIGURE 6**.



**FIGURE 6.** Installation of Portable Incubator Monitoring Tool with Short Message Service (SMS) notifications

#### 1) TESTING MPU6050 SENSOR

This test is done to determine the performance of the tool, starting with testing the tilt sensor on the accelerometer. The data taken is based on the slope of the angle 0°, 20°, 25° 70°, and 90° to the left, right, front, and back; then the sensor data is displayed on the serial monitor so that the results are in accordance with **TABLE 1**.



**FIGURE 7.** Testing of Alzheimer's patient surveillance tools

#### 2). TESTING MODULE GSM SIM800L

Testing on SIM800L begins the process of sending SMS from the module to the destination number (**FIGURE 7**). To find out, SIM800L can work well and can communicate with the microcontroller as a liaison to the GSM network from the microcontroller, which is used as a regulator of when and to which number SMS will be sent and the contents of short text messages (SMS) to be sent. The condition that is sent is when the supervisor sends the message "GPS ON" to SIM800L. Then when the MPU6050 sensor data shows the value as shown in **TABLE 1**.

**TABLE 1**  
**ACCELEROMETER SENSOR VALUE FOR FALL DETECTION**

Fall Direction	Patient's Condition			Information
	x	y	z	
Normal	0°	26° - 90°	21° - 90°	The patient is fine
Fall to the left	-65° - 90°	-25° - 0°	90°	The SMS is sent in the form of a patient's location link : <a href="http://www.google.com/map/place">www.google.com/map/place</a>
Fall to the right	65° - 90°	25° - 0°	90°	The SMS is sent in the form of a patient's location link : <a href="http://www.google.com/map/place">www.google.com/map/place</a>
Fall forward	70° - 90°	90°	20° - 0°	The SMS is sent in the form of a patient's location link : <a href="http://www.google.com/map/place">www.google.com/map/place</a>
Fall back	-70° - 90°	90°	-20° - 0°	The SMS is sent in the form of a patient's location link : <a href="http://www.google.com/map/place">www.google.com/map/place</a>

When the GPS module gets a signal, the message sent contains "Patient location [www.google.com/map/place](http://www.google.com/map/place)." While the GPS module did not get a signal, the message sent only "Patient location," which does not have a link to the longitude and latitude coordinates, as shown in Figure 8. The test results of the GSM SIM800L module can be seen in TABLE 2.

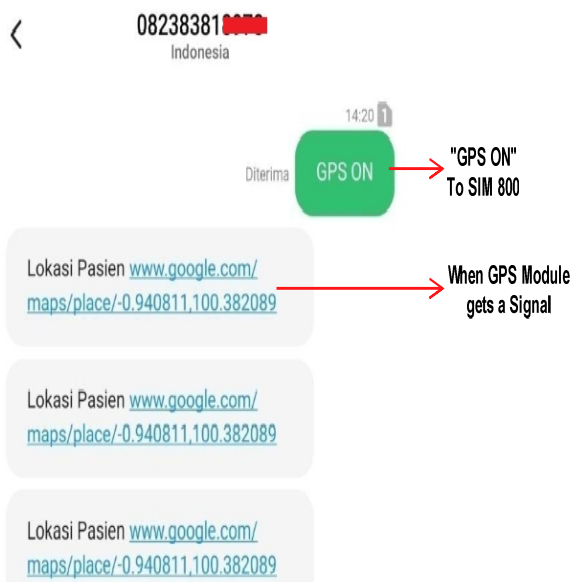

**FIGURE 8.** Testing Supervisor sends "GPS ON" message to determine patient position

**TABLE 2**  
**TEST RESULT MODULE GSM SIM800L**

Fall Direction	Patient's Condition			Notification	Information
	x	y	z		
Normal	0°	26° - 90°	21° - 90°	No	Operate properly
Fall to the left	-65° - 90°	-25° - 0°	90°	SMS	Operate properly
Fall to the right	65° - 90°	25° - 0°	90°	SMS	Operate properly
Fall forward	70° - 90°	90°	20° - 0°	SMS	Operate properly
Fall back	-70° - 90°	90°	-20° - 0°	SMS	Operate properly

3). TESTING MODULE GPS U-BLOK NEO

This test aims to determine how accurate the reading of the coordinates of the location is captured by GPS satellites using the Ublox Neo-6M module and calculate the difference in the shift of the coordinate reading point (latitude and longitude). The shift design of the reading position on the GPS module can be seen in FIGURE 9.

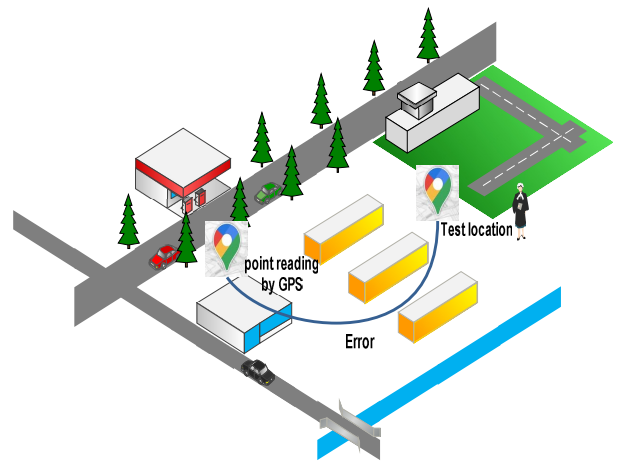

**FIGURE 9.** The shift design of the reading position on the GPS module

The coordinates of the test position are set at -0.927869, 100.433592. These coordinates were taken using the Google Maps application based on their actual location and position. Calculation of the distance between two points on a curved surface (spherical Earth theory) by utilizing latitude and longitude values using the Haversine Formula method [24][25]. This method is an equation for the use of navigation in order to calculate the distance between coordinates in a geographic projection system in Degrees Decimal (DD°). The results of the shift in the GPS reading point between the google map and the GPS module using the Haversine Formula can be seen in TABLE 3.

**TABLE 3**  
THE DIFFERENCE BETWEEN THE SHIFT FROM THE GPS READING POINT TO THE TEST POINT

No	Google Map		Modul GPS		Error (meter)
	Latitude1	Longitude1	Latitude2	Longitude2	
1	-0,927869	100,43359	-0,927845	100,43362	4,1003529
2	-0,927869	100,43359	-0,927843	100,43362	4,2484494
3	-0,927869	100,43359	-0,927842	100,43362	4,324885
4	-0,927869	100,43359	-0,92784	100,43362	4,4821235
5	-0,927869	100,43359	-0,927847	100,43361	3,1605848
6	-0,927869	100,43359	-0,927848	100,43361	3,0753263
7	-0,927869	100,43359	-0,927849	100,43361	2,9917714
8	-0,927869	100,43359	-0,92785	100,43361	2,9100668
9	-0,927869	100,43359	-0,92785	100,43361	2,9100668
10	-0,927869	100,43359	-0,92787	100,43359	0,2486131
11	-0,927869	100,43359	-0,927861	100,43359	0,916929
12	-0,927869	100,43359	-0,927864	100,43359	0,5987917
13	-0,927869	100,43359	-0,927867	100,43359	0,3144859
14	-0,927869	100,43359	-0,927868	100,43359	0,2486131
15	-0,927869	100,43359	-0,927869	100,43359	0,2223605
<b>Average</b>					<b>2,316</b>

**IV. DISCUSSION**

Based on TABLE 1, when the patient's condition was normal, the accelerometer sensor tilted  $x = 0^\circ$ ,  $y = 26^\circ - 90^\circ$ ,  $z = 21^\circ - 90^\circ$ . When the patient falls to the left, the patient in a tilt position  $x = -65^\circ - -90^\circ$ ,  $y = -25^\circ - 0^\circ$ ,  $z = 90^\circ$ . Furthermore, when the patient falls to the right, the patient in a tilt position  $x = 65^\circ - 90^\circ$ ,  $y = 25^\circ - 0^\circ$ ,  $z = 90^\circ$ . When the patient falls forward, the patient in a tilt position  $x = 70^\circ - 90^\circ$ ,  $y = 90^\circ$ ,  $z = 20^\circ - 0^\circ$ . Meanwhile, when the patient falls backwards  $x = -70^\circ - -90^\circ$ ,  $y = 90^\circ$ ,  $z = -20^\circ - 0^\circ$ . Changes in the angle value will affect the sensor value of the MPU6050 sensor. The greater the change in angle, the greater the sensor value of the MPU6050 sensor. So when the sensor value of the MPU6050 sensor shows the data value that has been set when it falls left, right, forward, and backward, SIM800L will send an SMS to the number 08526359xxxx. The SMS contains the link for the longitude and latitude coordinates only when the GPS module gets a signal. If when the MPU6050 sensor shows the Alzheimer's patient data has fallen and the GPS module does not get a signal, then the SMS sent will only contain "Patient location," which does not have a link for the longitude and latitude coordinates. Furthermore, testing the detection of tools for falls and prone incidents are carried out. The test results can be seen in

TABLE 4. Based on the experiments in TABLE 4, some falling activities such as falling on your back and falling on your stomach can be detected by the system as falling activities with an accuracy rate of 90%.

**TABLE 4**  
DETECTION TEST FALLS ON THE SYSTEM

Category	Number of experiment	Notification Fall		Accuracy %	Detection %	
		Yes	No		Yes	No
Face down	15	14	1	90	Yes	No
Recumbent	15	14	1	90	90	10
Total	30	28	2			

Testing the GSM SIM800L module in TABLE 2 proves that the measurement of angular rotation on the MPU6050 module is in accordance with the test results, where SMS will be sent to the number set on the device based on the acceleration value that has been tested in TABLE 1. SMS can be done depending on the availability and signal strength of the GSM card used. The module can send SMS with AT+CMGS commands and make phone calls with ATD commands.

In TABLE 3 there are values for latitude1 and longitude1 were the test points for the Google Maps application. The values of latitude2 and longitude2 were obtained from the results of data from testing the U-blox Neo-6M GPS module. So, the error value obtained by the GPS module from the coordinates measured using the Haversine Formula method. The 7th test to the 15th test the reading distance by the GPS module close to the test point location. This is because the GPS navigation system, while turned on, will try to listen to all satellites and wait for the nearest location report (TTFF / Time To First Fix). Listening to all the satellites and selecting the nearest location will take a long time because the navigation satellites will always move and will not be in the same position.

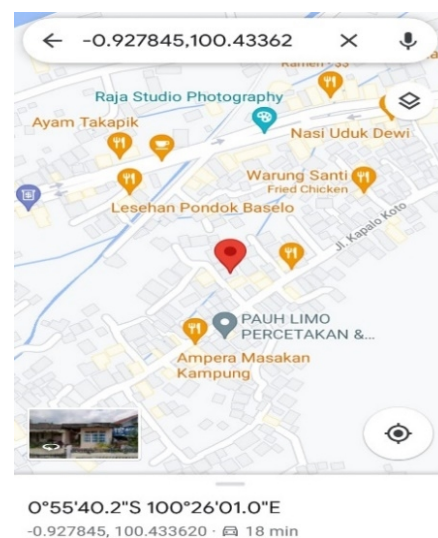

**FIGURE 10.** Tracking the position of sending SMS links at the test location

**FIGURE 10** shows that GPS has detected the test location at coordinates  $-0.927845, 100.433620$ , meaning that when compared to the location of the google maps reading, based on the Haversine Formula Method, the average shift distance of the GPS reading point was 2.39 meters. The system with SMS notifications and tracking on google maps can work well, starting from tilt detection, alarms, sending SMS with data from the GPS module. A similar study was also conducted by [23] using the line application as LINE BOT if the elderly were detected falling. The results showed the system could send alarms with high effectiveness. But in this study, the prototype still has limitations while used inside the room for the GPS and working properly outside the room.

## V. CONCLUSION

The aim of this research was to design and build a useful tool to determine the position and condition of Alzheimer's patients. At the same time, the sensor accelerometer MPU6050 in slope range  $-y = -25^\circ - 0^\circ$  the conditions of patients fall to the left. In the range  $y = 25^\circ - 0^\circ$  patients fall to the right, the range  $z = 20^\circ - 0^\circ$  patients fall to in front, and the range  $z = -20^\circ - 0^\circ$  patients fall to the back. The position of rotation point at X-axis which have slope slope  $x_y = 65^\circ - 90^\circ$ ,  $-x_y = -65^\circ - 90^\circ$ ,  $x_z = 70^\circ - 90^\circ$  dan  $-x_z = -70^\circ - 90^\circ$ . GPS U-BLOX NEO Module has difficulty reaching the satellite signal to determine the longitude and latitude position while inside the room and can get the longitude and latitude position easily outside the room. Once the GPS U-BLOX NEO Module gets the signal, then the GSM SIM800L module sends an SMS "Lokasi Pasien [www.google.com/map/place](http://www.google.com/map/place)" to 08526359xxxx. If the patient supervisor sent the SMS "GPS ON" to 08238381xxxx and push-button was pushed, or high condition and the patient fell to the left, right, in front, or to the back with the position shift of GPS Module reading to the testing point average is 2.39 meter. The future work still needs to reduce the distance between the real patient position and the result of the system and also need to find a good GPS module that works properly inside the room.

## REFERENCES

- [1] S. Wang, "Spectrum of Disease Severity," *Natl. Inst. Heal.*, vol. 78, no. 4, pp. 596–612, 2012, doi: 10.1002/msj.20279.Alzheimer.
- [2] G. McKhann, "the diagnosis of dementia due to Alzheimer's disease," *Alzheimers Dement*, vol. 7, no. 3, pp. 263–269, 2012, doi: 10.1016/j.jalz.2011.03.005.The.
- [3] Ricci, "Social Aspects of Dementia Prevention from a Worldwide to National Perspective: A Review on the International Situation and the Example of Italy," *Behav. Neurol.*, vol. 2019, 2019, doi: 10.1155/2019/8720904.
- [4] N. T. Aggarwal, M. Tripathi, H. H. Dodge, S. Alladi, and K. J. Anstey, "Trends in Alzheimer's disease and dementia in the Asian-Pacific region," *Int. J. Alzheimers. Dis.*, vol. 2012, 2012, doi: 10.1155/2012/171327.
- [5] "2020 Alzheimer's disease facts and figures," *Alzheimer's Dement.*, vol. 16, no. 3, pp. 391–460, 2020.
- [6] E. Caspi, "Wayfinding difficulties among elders with dementia in an assisted living residence," *Dementia*, vol. 13, no. 4, pp. 429–450, 2014, doi: 10.1177/1471301214535134.
- [7] J. E. Galvin, "Prevention of Alzheimer's Disease: Lessons Learned and Applied," *J. Am. Geriatr. Soc.*, vol. 65, no. 10, pp. 2128–2133, 2017, doi: 10.1111/jgs.14997.
- [8] H. Khodkari, S. G. Maghrebi, A. Asosheh, and M. Hosseinzadeh, "Smart Healthcare and Quality of Service Challenges," 9th Int. Symp. Telecommun. With Emphas. Inf. Commun. Technol. IST 2018, pp. 253–257, 2019, doi: 10.1109/ISTEL.2018.8661125.
- [9] A. Aulia, F. Tanzil, I. K. Wairooy, L. K. Gunawan, A. Cunwinata, and Albert, "A development of android-based mobile application for getting ideal weight," *Telkonnika (Telecommunication Comput. Electron. Control.*, vol. 16, no. 3, pp. 1289–1294, 2018, doi: 10.12928/TELKOMNIKA.v16i3.8342.
- [10] H. Fei and M. Ur-Rehman, "A Wearable Health Monitoring System," *2020 Int. Conf. UK-China Emerg. Technol. UCET 2020*, pp. 6–9, 2020.
- [11] D. Hemapriya, P. Viswanath, V. M. Mithra, S. Nagalakshmi, and G. Umarani, "Wearable medical devices - Design challenges and issues," *IEEE Int. Conf. Innov. Green Energy Healthc. Technol. - 2017, IGEHT 2017*, pp. 1–6, 2017.
- [12] M. Islam et al., "Android based heart rate monitoring and automatic notification system," 5th IEEE Reg. 10 Humanit. Technol. Conf. 2017, R10-HTC 2017, vol. 2018-January, pp. 436–439, 2018, doi: 10.1109/R10-HTC.2017.8288993.
- [13] D F. A. Khan and M. I. Khan, "Android based health care system for aged diabetic patients," *2016 3rd Int. Conf. Electr. Eng. Inf. Commun. Technol. iCEEiCT 2016*, 2017.
- [14] I. Sutedja, R. Bahana, and I. B. K. Manuaba, "Foods diary mobile application for diabetics," *Proc. 2020 Int. Conf. Inf. Manag. Technol. ICIMTech 2020*, no. August, pp. 228–232, 2020.
- [15] I. F. Zahra, I. D. G. H. Wisana, P. C. Nugraha, and H. J. Hassaballah, "Design a Monitoring Device for Heart-Attack Early Detection Based on Respiration Rate and Body Temperature Parameters," *Indones. J. Electron. Electromed. Eng. Med. Informatics*, vol. 3, no. 3, pp. 114–120, 2021.
- [16] M. A. Pertiwi, I. D. Gede Hari Wisana, T. Triwiyanto, and S. Sukaphat, "Measurement of Heart Rate, and Body Temperature Based on Android Platform," *Indones. J. Electron. Electromed. Eng. Med. Informatics*, vol. 2, no. 1, pp. 26–33, 2020.
- [17] A. Amritphale, N. Amritphale, and D. Dubey, "Smartphone applications providing information about stroke: Are we missing stroke risk computation preventive applications?," *J. Stroke*, vol. 19, no. 1, p. 117, 2017, doi: 10.5853/jos.2016.01004r.
- [18] D. Alhelal, A. K. Younis, and R. H. A. Al-Mallah, "Detection of brain stroke in the MRI image using FPGA," *Telkonnika (Telecommunication Comput. Electron. Control.*, vol. 14, no. 5, pp. 1307–1315, 2021.
- [19] H. A. Rahman, C. F. Yeong, K. X. Khor, and E. L. M. Su, "Important parameters for hand function assessment of stroke patients," *Telkonnika (Telecommunication Comput. Electron. Control.*, vol. 15, no. 4, pp. 1501–1511, 2017.
- [20] M. Irmansyah, E. Madona, and A. Nasution, "Design and application of portable heart rate and weight measuring tool for premature baby with microcontroller base," *Int. J. GEOMATE*, vol. 17, no. 61, pp. 195–201, 2019, doi: 10.21660/2019.61.ICEE12.
- [21] A. R. Anwary, M. Vassallo, and H. Bouchachia, "Monitoring of Prolonged and Asymmetrical Posture to Improve Sitting Behavior," *2020 Int. Conf. Data Anal. Bus. Ind. W. Towar. a Sustain. Econ. ICDABI 2020*, 2020.
- [22] M. Mubashir, L. Shao, and L. Seed, "A survey on fall detection: Principles and approaches," *Neurocomputing*, vol. 100, pp. 144–152, 2013, doi: 10.1016/j.neucom.2011.09.037.
- [23] A. Hakim, M. S. Huq, S. Shanta, and B. S. K. K. Ibrahim, "Smartphone Based Data Mining for Fall Detection: Analysis and Design," *Procedia Comput. Sci.*, vol. 105, no. December 2016, pp. 46–51, 2017, doi: 10.1016/j.procs.2017.01.188.
- [24] A. Suryana, F. Reynaldi, F. Pratama, G. Ginanjar, I. Indriansyah, and D. Hasman, "Implementation of haversine formula on the limitation of e-voting radius based on android," *Proc. - 2018 4th Int. Conf.*

*Comput. Eng. Des. ICCED 2018*, pp. 218–223, 2019.

- [25] I. Indrianto, M. N. I. Susanti, R. R. A. Siregar, J. P. Putri, and Y. Purwanto, "Smart taxi security system design with Internet of Things (IoT)," *Telkomnika (Telecommunication Comput. Electron. Control.*, vol. 17, no. 3, pp. 1250–1255, 2019.