

Manuscript received September 18, 2023; revised September 20, 2023; accepted November 12, 2023; date of publication Nov. 12, 2023

Digital Object Identifier (DOI): <https://doi.org/10.35882/ijeemi.v5i4.333>

Copyright © 2022 by the authors. This work is an open-access article and licensed under a Creative Commons Attribution-ShareAlike 4.0 International License ([CC BY-SA 4.0](https://creativecommons.org/licenses/by-sa/4.0/))

**How to cite:** Mohamad Sofie, Patrisius Kusi Olla, and Pramesti Kusumaningtyas, Fani Maduratni Chambali, "An IoT-based Baby Scales for Stunting Monitoring in Indonesia", Indonesian Journal of Electronics, Electromedical Engineering, and Medical Informatics, vol. 5, no. 4, pp. 217-223, November. 2023.

# An IoT-based Baby Scales for Stunting Monitoring in Indonesia

Mohamad Sofie, Patrisius Kusi Olla, Pramesti Kusumaningtyas, and Fani Maduratni Chambali

Departement of Electromedical Engineering, Sekolah Tinggi Ilmu Kesehatan Semarang

Corresponding author: Mohamad Sofie (e-mail: [msofie.ms@gmail.com](mailto:msofie.ms@gmail.com)).

**ABSTRACT** The Indonesian government has tried to do prevention stunting case by monitoring and recording the toddlers growth. The problems are the process of recording and entering toddler growth data is still done manually. This is not effective if done over a large area such as in Indonesia because it takes a long time to collect data and has a large possibility of recording errors. The aim of this research is to design an IoT-based baby scale by adding Node MCU ESP32 in to digital baby scales; so the data read by the scales recorded directly in the central data base. The scales are connected to the data base and web page via a WiFi network. The measurement data will be processed in the cloud to obtain a nutritional status classification. It makes the process of determining nutritional status faster. Based on the research conducted, the use of IoT-based baby scales can simplify the process of measuring toddlers' weight and height. The results of unit testing show that the tool is running well with the level of accuracy are 0,3% still within tolerance limits. The next research is expected to add location features, resumes per area and improve access levels on web pages for data security.

**INDEX TERMS** Stunting, Baby scales, IoT, Stunting monitoring.

## I. Introduction

One of the social problems in the health sector that is currently occurring is the high prevalence of stunting cases in Indonesia. Stunting is defined as a child's condition with a Z-score for height for age less than -2 standard deviations [1]. Stunting is an important problem, that potentially give negative impact to child development, quality of life and future of these stunted children. Stunting causes high morbidity and mortality such as life-threatening complications during birthing, increased infant mortality rates, reduced cognitive performance, poor intelligent quotients, emergence of chronic disease, reduced production capacity in adulthood, with loses in economic growth and social development of the country[2], [3]. Stunting in Indonesia has become a national issue, with a prevalence in children under five years of 31%, still higher than the normal WHO standard of 20%. It shows that progress in reduce and managing childhood stunting has been slow over the past decade[3]. Child stunting is associated with the following determinants in Indonesia are male sex, premature birth, short birth length, nonexclusive breastfeeding for the first 6 months, short maternal heighth, low maternal education, low household socio-economic status, living in a household with unimproved latrines and untreated drinking water, poor access to healthcare, and living in rural area[4], [5]. Various efforts have been made by the government to reduce prevalence of stunting cases in Indonesia. Stunting

convergence management framework to accelerating stunting reduction through system integration based on regional governance are leadership and staff[6], stunting analysis, digitizig stunting data, the readiness of stunting data management and open government [7], [8].

In other studies, stunting case management can be started from early detection of stunting cases from newborn, that requires inter-sectoral collaboration and programs[9]. Early detection is carried out by anthropometric measurements including body weight, height, head circumference and arm circumference to get Z-score and classify them into certain categories [9], [10]. The anthropometric measurement process is critical because measurement accuracy is an essential indicator to obtain accurate and high-quality data; moreover, errors in these measurements can affect interpretation. Inappropriate anthropometric measurements can lead to misclassification of nutritional status, intervention planning, and referrals[11].

The problems are the process of recording and entering toddler growth data is still done manually. Anthropometric measurements were carried out at the posyandu and data were collected through the puskesmas to the health service level which covers a wider area. Recording measurement results using the KMS book. It is not uncommon for KMS books to be lost, scattered or damaged. This is not effective if done over a large area such as in Indonesia because it takes a long time to collect data and has a large possibility of

recording errors. How to make an automatic baby scale that can simplify and speed up the measurement and reporting process is a fundamental question in this research. A new community health service method for recording and monitoring the nutritional status of infants and toddlers based IoT is presented in this paper. Modifications are made by adding IoT technology to baby scales, so the data collection process by telemetry will be faster and the percentage of human error can be reduced[12], [13]. Telemetry is the process of measuring the parameters of an object (object, space, natural conditions) whose results are sent to another place via cable or wirelessly. Telemetry is expected to provide convenience in measurement, monitoring and reduce barriers to obtaining information[14]. One of the technologies that supports the telemetry process is Internet of Things technology (IoT).

The IoT is a technology that innovates surrounding objects, gadgets, databases, applications with the internet so that dialy activities become easier and more efficient [15], [16]. The basic IoT system consist of hardware/physical things include sensors, internet connection and cloud data center; which the interaction between hardware that are connected automatically without user intervention and at any distance, the user only serves as a regulator or supervisor[17]–[20]. Lack of access to medical resources, growth of the elderly population with cronic diseases and their needs for remote monitoring, an increase in medical cost, and the desire for the telemedicine in developing countries, make the IoT an interesting subject in healthcare system [21]–[26], specially during Covid-19 pandemic[27]–[30]. The factor that led to the merging of IoT and Cloud Data Center are cloud provides unlimited, low-cost and on-demand storage capacity, IoT system cloud perform real-time processing of data thus facilitating highly responsive applications, monitoring and control things on a real-time basis through remote locations, any time any where availability of resources, various devices can connect and interact with cloud[18], [31]–[34].

**II. Material And Methods**

The design of baby scales has two parts, hardware and software. In the hardware section, digital baby scales are modified with the addition Node MCU ESP 32 which allows baby scales to be connected to the internet via a wifi network so the measurement data from the posyandu can be directly conveyed to the data center. In the software section, a web page are create to manage the results of anthropometric measurements for toddlers and another personal data. The stunting toddler classification is also added to the toddler anthropometric measurement web page.

**A. The Diagram Block**

To implement a system of baby scales with IoT for stunting monitoring, research uses the proposed equipment in baby scales as depicted in FIGURE 1 and

FIGURE 2, which included a modul power supply, sensors, a modul controller, and touchscreen LCD.

Modifications were made by adding the ESP 32 module to digital baby scales. The ESP32 is a family of low-cost, low-power system on-chip microcontrollers with Wi-Fi and Bluetooth capabilities and a highly integrated structure powered by a Tensilica Xtensa LX6 dual-core microprocessor. Loadcell sensor and HX711 are components for measuring body weight; while the encoder module is a component for measuring the toddler's height. Baby scales are also equipped with an LCD to display the interface. The data will also be stored in the cloud data center and can be viewed on the web page.

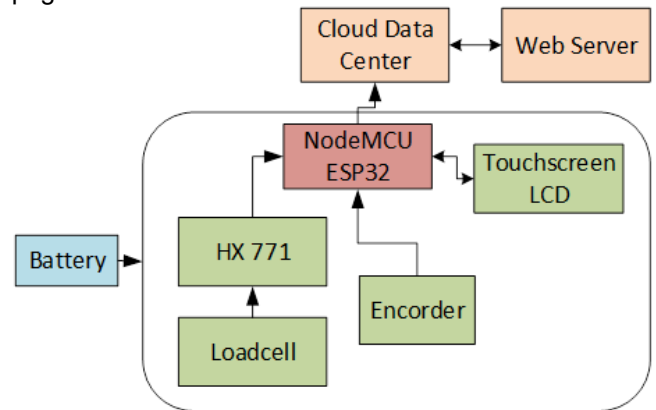

FIGURE 1. The diagram block of the system circuit

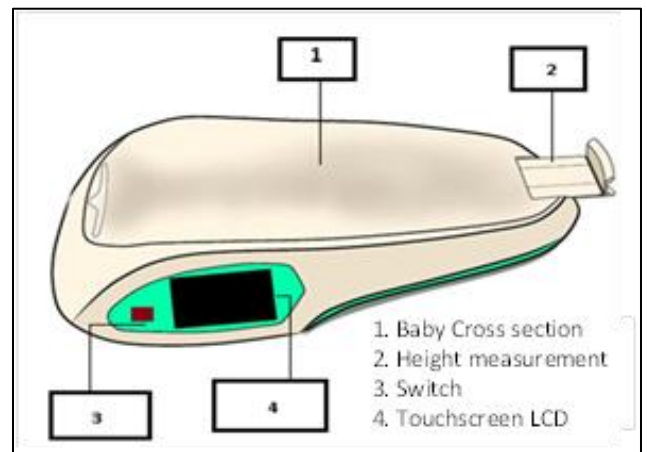

FIGURE 2. Design of IoT-based baby scales

**B. Work Flow Diagram**

The work flow of IoT-based baby scales can be seen in FIGURE 3. Baby scales require calibration at the first measurement after the instrument is switched on. For subsequent measurements there is no need for the calibration process again. Data on the baby's name, ID number, baby's date of birth, and gender need to be entered in the IoT-based baby scales system. The scales are equipped with an edit menu and a save menu for editing and saving child identity data. Measurement history can also be deleted using the delete menu.

The nutritional status information system for children was built using the PHP programming language and

MySQL database. Assessment of children's nutritional status is carried out by comparing the results of measurements of weight and length/height with the Children's Anthropometric Standards. The classification of nutritional status assessment based on the Anthropometric Index corresponds to the category of nutritional status in the WHO Child Growth Standards for children aged 0-5 years. Body Weight Index for Length/Height (BB/PB or BB/TB) This BB/PB or BB/TB index illustrates whether a child's weight is appropriate for the growth in length/height. This index can be used to identify wasted, severely wasted children and children who are possible risk of overweight. Table 1 shows the index of weight according to height according to the Minister of Health Regulation, 2020 (TABLE 1).

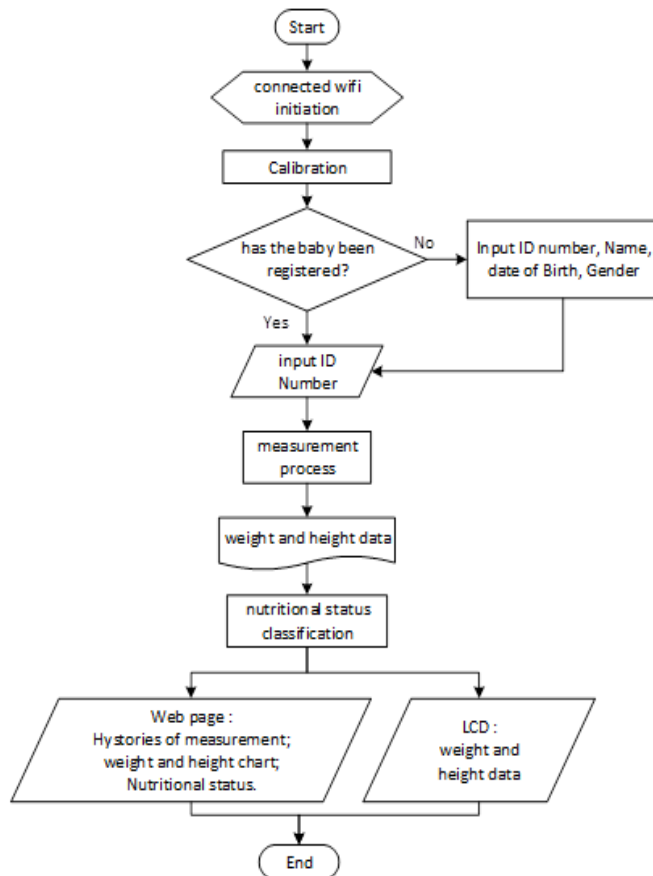

FIGURE 3. The flowchart of the system

TABLE 1

Index of weight according to height for children ages 0-60 month

| Classifications of nutritional status | Z-Score               |
|---------------------------------------|-----------------------|
| Severely Wasted                       | <- 3 SD               |
| Wasted                                | -3 SD until <-2 SD    |
| Normal                                | -2 SD until +1 SD     |
| Possible risk or overweight           | > + 1 SD until + 2 SD |
| Overweight                            | > + 2 SD until + 3 SD |
| Obese                                 | > + 3 SD              |

The nutritional status classification pseudocode is as follows.

```

weight, height, SD : float
read (weight)
read (height)
SD = weight/height
if SD = 0 then write "Error" else
if SD < - 3 then write "Gizi Buruk" else
if SD < -2 then write "Gizi Kurang" else
if SD < 1 then write "Gizi Baik" else
if SD < 2 then write "Beresiko Gizi Lebih" else
if SD < 3 then write "Gizi Lebih" else
if SD > 3 then write "Obesitas"
end if
    
```

III. Result

In this section, the implementation and working of the system baby scales in laboratory scenario for unit testing are explained. Unit testing is carried out to ensure the function of all features is running well and the accuracy of the measurement results is the same as the scales on the market. The complete process of measuring by IoT-based baby scales is explained in the following process sequence:

- Step 1 : Turn on the baby scales and connect to the wifi network.
- Step 2 : Then calibrate the baby scales. Don't forget to save the calibration settings so that the measured data is accurate.
- Step 3 : Input data name, date of birth, gender and ID number for a new measurement; then save and return to the main menu. skip this step if the baby to be measured is already registered.
- Step 4 : Call back using the id number or name and take weight and height measurements according to the baby's identity.
- Step 5 : The measurement results will be displayed on the LCD and stored in the cloud data center which can be accessed via a web page. The display on the web page and LCD can be seen in Figures 4 (a), (b), (c), (d) and Figure 5.

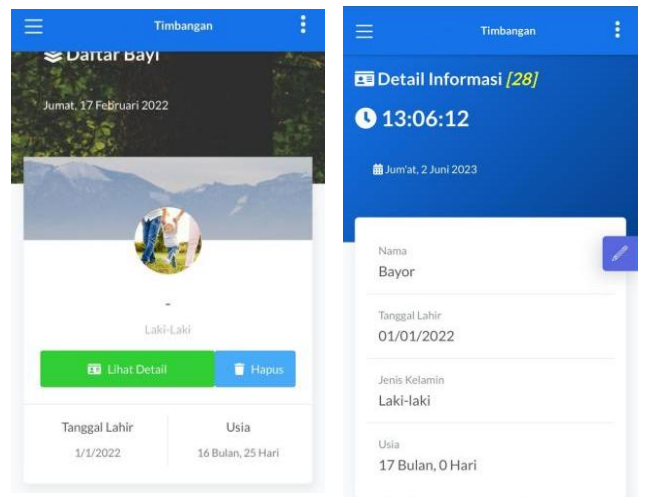

FIGURE 4 (a). The display of baby's information on the webpage



FIGURE 4 (b). The display of the result on the webpage

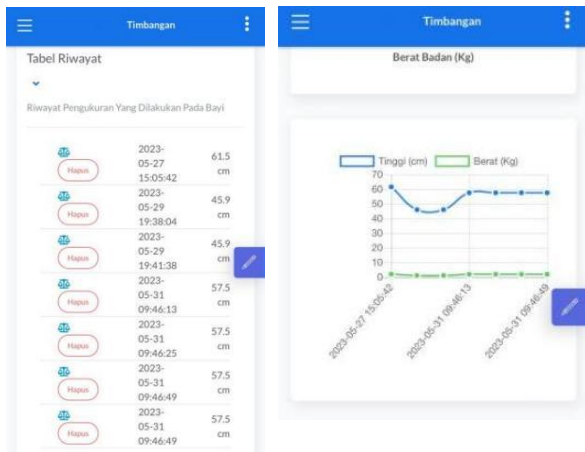

FIGURE 4 (c). The display of history on the webpage

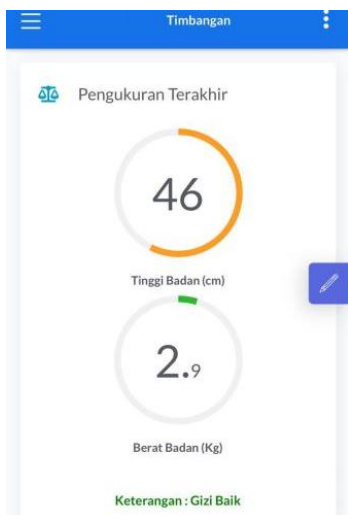

FIGURE 4 (d). The display of nutrition classification on the webpage



Figure 5. The LCD's display

#### IV. Unit Testing

There are 3 types of tests carried out on this IoT-based baby scales. The first is a function test to find out all the features of the tool are running properly, the results are listed in TABLE 2.

TABLE 2  
The result of unit function test

| No | Feature   | Result       |
|----|---|--------------|
| 1  | Login and connect wifi                                      | running well |
| 2  | Self calibration  | running well |
| 3  | Input baby's identity from the LCD                          | running well |
| 4  | Displays baby's identity on the LCD                         | running well |
| 5  | Displays measurement results on the LCD                     | running well |
| 6  | Edit menu of baby's identity from the LCD                   | running well |
| 7  | Delete menu of baby's identity from the LCD                 | running well |
| 8  | Displays baby's identity on the web page                    | running well |
| 9  | Displays measurement results on the web page                | running well |
| 10 | Displays graphic results on the web page                    | running well |
| 11 | Displays hystorical results on the web page                 | running well |
| 12 | Edit menu of baby's identity from the web page              | running well |
| 13 | Delete menu of baby's identity and result from the web page | running well |

The second is a test of the accuracy of the loadcell sensor in measuring body weight using calibrated weights, the results can be seen in TABLE 3.

TABLE 3  
The result of the accuracy of loadcell test

| No. | Load  | I     | II    | III   | Mean  | % error |
|-----|-------|-------|-------|-------|-------|---------|
| 1.  | 1 kg  | 1,03  | 1,03  | 1,03  | 1,03  | 0,3 %   |
| 2.  | 2 kg  | 2,07  | 2,07  | 2,07  | 2,07  | 0,3 %   |
| 3.  | 3 kg  | 3,10  | 3,10  | 3,10  | 3,10  | 0,3 %   |
| 4.  | 4 kg  | 4,13  | 4,13  | 4,13  | 4,13  | 0,3 %   |
| 5.  | 5 kg  | 5,16  | 5,16  | 5,16  | 5,16  | 0,3 %   |
| 6.  | 6 kg  | 6,20  | 6,20  | 6,20  | 6,20  | 0,3 %   |
| 7.  | 7 kg  | 7,23  | 7,23  | 7,23  | 7,23  | 0,3 %   |
| 8.  | 8 kg  | 8,26  | 8,26  | 8,26  | 8,26  | 0,3 %   |
| 9.  | 9 kg  | 9,30  | 9,30  | 9,30  | 9,30  | 0,3 %   |
| 10. | 10 kg | 10,33 | 10,33 | 10,33 | 10,33 | 0,3 %   |
| 11. | 15 kg | 15,50 | 15,50 | 15,50 | 15,50 | 0,3 %   |
| 12. | 20 kg | 20,68 | 20,68 | 20,68 | 20,68 | 0,3 %   |

The third is the accuracy test of the encoder module for measuring body height using a calibrated ruler, the results are shown in TABLE 4.

TABLE 4  
The Result of the accuracy of encoder test

| No. | Standard Ruler Reading (cm) | I (cm) | II (cm) | III (cm) | Mean (cm) | % error |
|-----|-----------------------------|--------|---------|----------|-----------|---------|
| 1.  | 46                          | 46     | 46      | 46       | 46        | 0 %     |
| 2.  | 50                          | 51,23  | 51,23   | 51,23    | 51,23     | 0,02 %  |
| 3.  | 60                          | 61,8   | 61,73   | 61,73    | 61,75     | 0,02 %  |
| 4.  | 70                          | 72,26  | 72,66   | 72,40    | 72,44     | 0,03 %  |
| 5.  | 80                          | 82,8   | 82,93   | 83,03    | 82,92     | 0,03 %  |

**V. Discussion**

From the function test performed it is known that the baby scales runs well. The accuracy of the tool is still within the tolerance threshold. Measurement results will produce primary data that is accurate and can be processed for other needs. What is interesting in this research is that the measurement results can be displayed graphically. This makes it easier to read the measurement history for officers who are familiar with KMS reports. It also can be viewed at any time anywhere. This makes it easier for health workers to monitor the development of the nutritional status of toddlers in their area. Recording of weight and height is also automatically recorded to the data center so that recording errors due to human errors do not occur again. The risk because the KMS book is lost or not carried is also zero because the recording process is automatic. It would be better if some features were further developed to support the use of this tool on the end user side, such as adding measurement locations and residential addresses, so the percentage of stunted toddlers are in that area can be seen from the data. Data on the percentage of stunting under five in an area can be the basis for formulating policies in the management of stunting prevention. Access levels on web pages also need to be added to maintain the confidentiality of personal data.

**VI. Conclusions**

Based on the research conducted, it can be seen that the use of IoT-based baby scales can simplify the process of measuring toddlers' weight and height. A feature that displays a child's nutritional status makes the process of determining nutritional status faster. The results of unit testing show that the tool is running well with the level of accuracy still within tolerance limits. The next research is expected to add location features, resumes per area and improve access levels on web pages.

**References**

[1] J. L. Leroy and E. A. Frongillo, "Perspective: What Does Stunting Really Mean? A Critical Review of the Evidence," *Advances in Nutrition*, vol. 10, no. 2. Oxford University Press, pp. 196–204, Mar. 01, 2019. doi: 10.1093/advances/nmy101.

[2] C. M. Wright, J. MacPherson, R. Bland, P. Ashorn, S. Zaman, and F. K. Ho, "Wasting and Stunting in Infants and Young Children as Risk Factors for Subsequent Stunting or Mortality: Longitudinal Analysis of Data from Malawi, South Africa, and Pakistan," *J Nutr*, vol. 151, no. 7, pp. 2022–2028, Jul. 2021, doi: 10.1093/JN/NXAB054.

[3] H. S. Mediani, "Predictors of Stunting Among Children Under Five Year of Age in Indonesia: A Scoping Review," *Glob J Health Sci*, vol. 12, no. 8, p. 83, Jun. 2020, doi: 10.5539/gjhs.v12n8p83.

[4] T. Beal, A. Tumilowicz, A. Sutrisna, D. Izwardy, and L. M. Neufeld, "A review of child stunting determinants in Indonesia," *Maternal and Child Nutrition*, vol. 14, no. 4. Blackwell Publishing Ltd, Oct. 01, 2018. doi: 10.1111/mcn.12617.

[5] Marni, A. Z. Abdullah, R. M. Thaha, H. Hidayanty, S. Sirajuddin, and M. Syafar, "Risk factor and interventions of behavioral changing strategy in acceleration of stunting

prevention: A systematic review," *Enferm Clin*, vol. 31, pp. S636–S639, Dec. 2021, doi: 10.1016/J.ENFCLI.2021.07.008.

[6] Z. A. Bhutta *et al.*, "How countries can reduce child stunting at scale: Lessons from exemplar countries," *American Journal of Clinical Nutrition*, vol. 112, pp. 894S-904S, Jul. 2020, doi: 10.1093/ajcn/nqaa153.

[7] A. Prasetyo *et al.*, "Stunting Convergence Management Framework through System Integration Based on Regional Service Governance," *Sustainability (Switzerland)*, vol. 15, no. 3, Feb. 2023, doi: 10.3390/su15031821.

[8] S. Palutturi, A. Syam, A. Asnawi, and Hamzah, "Stunting in a political context: A systematic review," *Enferm Clin*, vol. 30, pp. 95–98, Jun. 2020, doi: 10.1016/J.ENFCLI.2019.10.049.

[9] D. K. Sunjaya, D. M. D. Herawati, N. Indraswari, G. Megawati, and B. Sumintono, "Training and Assessing Model for the Ability of Community Health Volunteers in Anthropometric Measurement Using the Rasch Stacking and Racking Analyses," *J Environ Public Health*, vol. 2021, 2021, doi: 10.1155/2021/5515712.

[10] M. A. Ezzat, E. M. Albassam, E. A. Aldajani, R. A. Alaskar, and E. B. Devol, "Implementation of new indicators of pediatric malnutrition and comparison to previous indicators," *Int J Pediatr Adolesc Med*, vol. 9, no. 4, pp. 216–224, Dec. 2022, doi: 10.1016/J.IJPAM.2022.12.003.

[11] A. L. Vegelin, L. J. C. E. Brukx, J. J. Waelkens, and J. Van Den Broeck, "Influence of knowledge, training and experience of observers on the reliability of anthropometric measurements in children," *Ann Hum Biol*, vol. 30, no. 1, pp. 65–79, Jan. 2003, doi: 10.1080/03014460210162019.

[12] K. Lawal and H. N. Rafsanjani, "Trends, benefits, risks, and challenges of IoT implementation in residential and commercial buildings," *Energy and Built Environment*, vol. 3, no. 3, pp. 251–266, Jul. 2022, doi: 10.1016/J.ENBENV.2021.01.009.

[13] T. Domínguez-Bolaño, O. Campos, V. Barral, C. J. Escudero, and J. A. García-Naya, "An overview of IoT architectures, technologies, and existing open-source projects," *Internet of Things*, vol. 20, p. 100626, Nov. 2022, doi: 10.1016/J.IOT.2022.100626.

[14] E. A. Alizadeh *et al.*, "Thirty years of telemetry-based data acquisition for cardiovascular drug safety evaluation: Applications and optimization," *J Pharmacol Toxicol Methods*, vol. 122, p. 107279, Jul. 2023, doi: 10.1016/J.VASCN.2023.107279.

[15] Q. Wang, X. Zhu, Y. Ni, L. Gu, and H. Zhu, "Blockchain for the IoT and industrial IoT: A review," *Internet of Things*, vol. 10, p. 100081, Jun. 2020, doi: 10.1016/J.IOT.2019.100081.

[16] V. V. Prabhakar, C. S. Belarmin Xavier, and K. M. Abubeker, "A Review on Challenges and Solutions in the Implementation of AI, IoT and Blockchain in Construction Industry," *Mater Today Proc*, Apr. 2023, doi: 10.1016/J.MATPR.2023.03.535.

[17] F. Montori *et al.*, "An IoT Toolchain Architecture for Planning, Running and Managing a Complete Condition Monitoring Scenario," *IEEE Access*, vol. 11, pp. 6837–6856, 2023, doi: 10.1109/ACCESS.2023.3237971.

[18] T. Ghosh, A. Roy, and S. Misra, "B2H: Enabling delay-tolerant blockchain network in healthcare for Society 5.0," *Computer Networks*, vol. 210, p. 108860, Jun. 2022, doi: 10.1016/J.COMNET.2022.108860.

[19] J. A. Stankovic, "Research directions for the internet of things," *IEEE Internet Things J*, vol. 1, no. 1, pp. 3–9, Feb. 2014, doi: 10.1109/JIOT.2014.2312291.

[20] A. Al-Fuqaha, M. Guizani, M. Mohammadi, M. Aledhari, and M. Ayyash, "Internet of Things: A Survey on Enabling Technologies, Protocols, and Applications," *IEEE Communications Surveys and Tutorials*, vol. 17, no. 4, pp. 2347–2376, Oct. 2015, doi: 10.1109/COMST.2015.2444095.

[21] M. Haghi Kashani, M. Madanipour, M. Nikravan, P. Asghari, and E. Mahdipour, "A systematic review of IoT in healthcare: Applications, techniques, and trends," *Journal of Network and Computer Applications*, vol. 192, p. 103164, Oct. 2021, doi: 10.1016/J.JNCA.2021.103164.

[22] A. N. Navaz, M. A. Serhani, H. T. El Kassabi, N. Al-Qirim, and H. Ismail, "Trends, Technologies, and Key Challenges in

- Smart and Connected Healthcare," *IEEE Access*, vol. 9, pp. 74044–74067, 2021, doi: 10.1109/ACCESS.2021.3079217.
- [23] S. M. R. Islam, D. Kwak, M. H. Kabir, M. Hossain, and K. S. Kwak, "The internet of things for health care: A comprehensive survey," *IEEE Access*, vol. 3, pp. 678–708, Jun. 2015, doi: 10.1109/ACCESS.2015.2437951.
- [24] M. N. Bhuiyan, M. M. Rahman, M. M. Billah, and D. Saha, "Internet of Things (IoT): A Review of Its Enabling Technologies in Healthcare Applications, Standards Protocols, Security, and Market Opportunities," *IEEE Internet of Things Journal*, vol. 8, no. 13. Institute of Electrical and Electronics Engineers Inc., pp. 10474–10498, Jul. 01, 2021. doi: 10.1109/JIOT.2021.3062630.
- [25] G. Ioppolo, F. Vazquez, M. G. Hennerici, and E. Andrès, "Medicine 4.0: New technologies as tools for a society 5.0," *Journal of Clinical Medicine*, vol. 9, no. 7. MDPI, pp. 1–4, Jul. 01, 2020. doi: 10.3390/jcm9072198.
- [26] M. Hassanaliheragh *et al.*, "Health Monitoring and Management Using Internet-of-Things (IoT) Sensing with Cloud-Based Processing: Opportunities and Challenges," in *Proceedings - 2015 IEEE International Conference on Services Computing, SCC 2015*, Institute of Electrical and Electronics Engineers Inc., Aug. 2015, pp. 285–292. doi: 10.1109/SCC.2015.47.
- [27] M. Javaid and I. H. Khan, "Internet of Things (IoT) enabled healthcare helps to take the challenges of COVID-19 Pandemic," *J Oral Biol Craniofac Res*, vol. 11, no. 2, pp. 209–214, Apr. 2021, doi: 10.1016/J.JOBCR.2021.01.015.
- [28] R. Zgheib, G. Chahbandarian, F. Kamalov, H. El Messiry, and A. Al-Gindy, "Towards an ML-based semantic IoT for pandemic management: A survey of enabling technologies for COVID-19," *Neurocomputing*, vol. 528, pp. 160–177, Apr. 2023, doi: 10.1016/J.NEUCOM.2023.01.007.
- [29] S. M. Ali *et al.*, "Drivers for Internet of Things (IoT) adoption in supply chains: Implications for sustainability in the post-pandemic era," *Comput Ind Eng*, vol. 183, p. 109515, Sep. 2023, doi: 10.1016/J.CIE.2023.109515.
- [30] S. S. Vedaei *et al.*, "COVID-SAFE: An IoT-based system for automated health monitoring and surveillance in post-pandemic life," *IEEE Access*, vol. 8, pp. 188538–188551, 2020, doi: 10.1109/ACCESS.2020.3030194.
- [31] A. Kumar, R. Krishnamurthi, A. Nayyar, K. Sharma, V. Grover, and E. Hossain, "A Novel Smart Healthcare Design, Simulation, and Implementation Using Healthcare 4.0 Processes," *IEEE Access*, vol. 8, pp. 118433–118471, 2020, doi: 10.1109/ACCESS.2020.3004790.
- [32] N. Taimoor and S. Rehman, "Reliable and Resilient AI and IoT-Based Personalised Healthcare Services: A Survey," *IEEE Access*, vol. 10, pp. 535–563, 2022, doi: 10.1109/ACCESS.2021.3137364.
- [33] M. N. Bhuiyan *et al.*, "Design and Implementation of a Feasible Model for the IoT Based Ubiquitous Healthcare Monitoring System for Rural and Urban Areas," *IEEE Access*, 2022, doi: 10.1109/ACCESS.2022.3202551.
- [34] M. Zheng and S. Bai, "Implementation of Universal Health Management and Monitoring System in Resource-Constrained Environment Based on Internet of Things," *IEEE Access*, vol. 9, pp. 138744–138752, 2021, doi: 10.1109/ACCESS.2021.3101909.