

Manuscript received December 31, 2022; revised January 21, 2023; accepted February 02, 2023; date of publication May 25, 2023

Digital Object Identifier (DOI): <https://doi.org/10.35882/ijeemi.v5i2.278>

Copyright © 2023 by the authors. This work is an open-access article and licensed under a Creative Commons Attribution-ShareAlike 4.0 International License ([CC BY-SA 4.0](https://creativecommons.org/licenses/by-sa/4.0/))

How to cite: Farisy Azis Satria Wardhana, Anita Miftahul Maghfiroh, Dyah Titisari, Sumber, and Vugar Abdullayev, "Analysis of Temperature Distribution in Blood Banks Through Storage of Measurement Results with IoT Monitoring in the Blood Donation Unit of Indonesian Red Cross Surabaya", Indonesian Journal of Electronics, Electromedical Engineering, and Medical Informatics, vol. 5, no. 2, pp.101-107, May. 2023

Analysis of Temperature Distribution in Blood Banks Through Storage of Measurement Results with IoT Monitoring in the Blood Donation Unit of Indonesian Red Cross Surabaya

Farisy Azis Satria Wardhana¹, Anita Miftahul Maghfiroh¹, Dyah Titisari¹, Sumber¹, and Vugar Abdullayev²

¹Department of Electromedical Engineering Poltekkes Kemenkes, Surabaya

²Azerbaijan State Oil and Industry University, Azerbaijan

Corresponding author: Anita Miftahul Maghfiroh (anitamiftah@poltekkesdepkes-sby.ac.id).

ABSTRACT Temperature or temperature is an indicator of the degree of heat of an object. Cold chain or cold chain is a supply chain system that considers the temperature level in the process. Cold chain to keep frozen or chilled products in an environment with a certain temperature during production, storage, transportation, processing and sales. This is intended to maintain product quality. The purpose of this study was to determine the temperature distribution in the Blood bank at Blood Transfusion Unit Indonesian Red Cross Surabaya City which was used for storage of blood products. By using the ESP32 system and the DS18B20 temperature sensor which will then be monitored via IoT, it will make it easier for users to monitor. The results of these measurements will be stored in a micro SD card for analysis. The data is processed by Non-Parametric Test resulting in an interpretation that the temperature of each shelf is different due to the difference in the location of the sensor placement. The temperature difference is also influenced by the pattern of use and the process of heat transfer from the bottom to the top of the shelf. This research was considered successful with the result of the highest temperature distribution being 3°C and the lowest being 2°C. The location of these racks can be useful in determining day-to-day monitoring measuring points. This value has met the standard for storage of blood products, which is in the range of 2°C-6°C.

INDEX TERMS Blood Bank, Blood Product, Cold Chain, DS18B20, ESP32, IoT, Micro SD Card, Temperature

I. Introduction

Temperature or temperature is an indicator of the degree of heat of an object. Simply put, the higher the temperature of an object, the hotter the object. Microscopically, temperature shows the energy possessed by an object. A cold chain or cold chain is a supply chain system that considers the temperature level in the process. Cold chain to keep frozen or chilled products in an environment with a certain temperature during production, storage, transportation, processing, and sales. This is intended to maintain product quality. In the blood storage area in the Blood Donation Unit, hereinafter referred to as the blood transfusion unit, the temperature is very necessary because it will affect the quality of stored blood products. The current problem is that only a few officers at the blood transfusion unit know how the condition of the product storage area is. Storage of red blood cells at low temperatures in the blood bank can slow down the aging process of red blood cells. During storage, there is an accumulation of biochemical substances in red blood cells, a change in the shape of red blood cells, and an accumulation of

by-products. Storage at low temperatures also inhibits the cleansing mechanism of healthy red blood cells, so red blood cells must coexist with the remains of damaged cells. Therefore, the temperature in the blood bank can affect the aging rate of red blood cells during storage [1].

N.N. Mahzan et.al presents the design and development of a data logger system with a large memory capacity to store data from several input channels. The data logger prototype was tested, demonstrating the ability to log data for up to 6 years unattended [2]. To find out how the performance conditions in the cold chain, researcher C. Vancea 2011 conducted monitoring and data recording using wireless with SD Card storage media, but this study has a communication range that is not too far [3][4]. In addition, K. Chen in 2011 also conducted a research entitled Applying back propagation network to cold chain temperature monitoring which discusses temperature monitoring in the cold chain. This monitoring is carried out by radio frequency and also recording the measurement results on each cold

storage truck. However, this study did not write about the temperature distribution in each cold storage [5]. K. Umamaheswari et.al make refrigerators by sending temperature data to users. monitor the temperature system inside the storage box using the LM35 temperature sensor. The electrical output from the temperature sensor is then sent to the Arduino, which is connected to the Raspberry Pi. The Raspberry Pi is programmed to send notifications to users via a mobile app, providing real-time information about the temperature inside the storage box [6]. In 2015 W. Liao conducted research entitled Sensor Integrated Antenna Design for Applications in Cold Chain Logistic Services discussing distribution in cold boxes using temperature sensors monitored on smartphones. The communication uses Bluetooth media so that the data transmission range cannot be too far. In addition, the cold box studied also did not specify the items to be stored in the storage area [7]. In 2016 J. Bellman-Flores with his research entitled Analysis of the flow and temperature distribution inside the compartment of a small refrigerator analyzed the temperature distribution in a conventional refrigerator using a thermal camera. But the study did not show the setting temperature. In addition, the refrigerator used is a conventional refrigerator that is not intended for medical activities [8]. V. Valcon also wrote his research in analyzing vaccine storage using a temperature data recorder, but this method does not indicate what happens after reading the data [9]. Sumet Umchid et.al conducted research on temperature control in the blood bank design that the researchers made, the system in the blood bank that the researchers made using Peltier as a cold source, and PID control to achieve the required temperature of the blood. The measurement results obtained an error of $\pm 10.984\%$ [10]. Lau Jye Hui et.al monitored the temperature of the blood bank in a wireless system using ZigBee and displayed it on a computer using LabVIEW. The advantage of the system is that there is an alarm when the temperature in the blood bank exceeds 5°C and is less than 3°C [11]. Vishal Kumar Gupta et.al explores the potential benefits of applying IoT technology to cold supply chains, particularly in the context of fresh food products [12][13]. This proves that the combination of IoT in monitoring temperature is very helpful. S.Kiruthika monitors the temperature on the blood bank and integrates it with IOT which is displayed on the web. In this study it is possible to identify the blood supply that can be accessed from the blood donation center displayed on the web page [14][15].

Based on the reference of research that has been done previously, the author will analyze the distribution of temperature in cold storage on blood products. This study aimed to determine the temperature distribution in the Blood bank at the blood transfusion unit Indonesian red cross Surabaya City which was used for storing blood products. In addition, this activity is also in line with government regulations that whenever

possible there is a temperature recorder in every cold storage of blood product. This is by the Regulation of the Minister of Health No. 91 concerning Blood Transfusion Service Standards. The contribution of this research is that it can provide a solution for Blood Transfusion Units that do not have cold storage monitoring devices and can also assist in filling in CAPA (Corrective Action Preventive Action) for management if the stored blood products do not match the blood specified in Product Specifications.

The purpose of this study was to investigate and analyze the temperature distribution within the Blood Transfusion Unit of the Indonesian Red Cross in Surabaya City. Specifically, the focus was on understanding the temperature conditions in the Blood Bank where blood products are stored. Maintaining appropriate temperature levels is critical for preserving the quality and safety of blood products, ensuring that they remain viable and free from contamination during storage. His study contributes to the enhancement of blood product storage practices at the Indonesian Red Cross in Surabaya City, supporting their mission of providing safe and high-quality blood products for transfusion purposes. Additionally, the study's methodology and findings may serve as a reference for other blood transfusion units seeking to improve their temperature management systems.

II. Material and Methods

A. Experimental Setup

In this study, 3 sensors were placed on 3 blood bank racks, each of which was immersed in a glycerol solution. The temperature will be displayed on the IoT BLYNK and also the measurement results will be stored on the micro-SD Card. The data is processed by Non-Parametric Test resulting in an interpretation that the temperature of each shelf is different due to the difference in the location of the sensor placement.

B. Materials And Tool

This data logger consists of an ESP32 module with Arduino programming, an SD Card module, an SD Card, and a DS18B20 temperature sensor [16]. for supporting materials in the form of water and glycerol.

C. Experiment

Data collection was carried out on a blood bank at Blood Transfusion Unit Indonesian Red Cross Surabaya for 24 hours with a measurement interval of 1 minute [17]. The measurement results will be stored automatically on the SD Card which will then be processed and compared with the storage requirements of blood products.

D. The Diagram Block

FIGURE 1 shows that the temperature from the refrigerator will be read by each temperature sensor DS18B20 and then the sensor will automatically convert it into a digital data [18]. Then the digital data from the 3 temperature sensors will be processed again by the ESP32 model [19]. Processing is done to read digital data to be converted so that it can be displayed on an external monitor. After being processed by the

ESP32 module, the data will be added to the time data from the NTP server. From the data that has been added by the NTP server, it will be processed again by the SD Card module to be stored on the SD card in .csv format. In addition, the processed ESP32 data will be sent to the BLYNK server which will then be displayed on the BLYNK application [20].

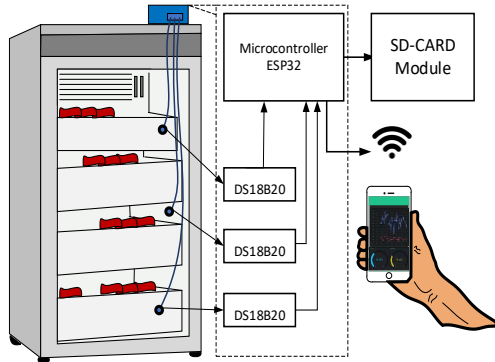

FIGURE 1. The diagram block

E. The Flowchart

FIGURE 2 shows the program starting with the initials of the program, namely the processing of the temperature sensor by the ESP32 module. The processed temperature sensor results will be sent to the BLYNK server. Once sent, the data will also be added to the data by the RTC module for time information. The results of the data will be processed by the SD Card module to be stored on the SD Card. Processing data and storing it on an SD card is a common task in various electronic applications, such as data logging, sensor data storage, and more. The SD Card module acts as an interface between the microcontroller (or other data source) and the SD card itself, facilitating data transfer and storage. Keep in mind that the specific implementation details and the communication protocols used will depend on the hardware and software you are working with.

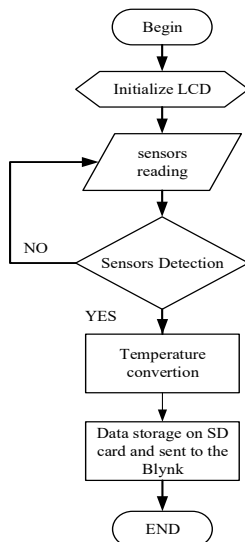

Figure 2. The Flowchart

F. Analog

FIGURE 3 shows the circuit shown in This circuit consists of an ESP32 module[21], a micro SD Card module, and a DS18B20 digital temperature sensor. This circuit is given an input voltage of 5V. The ESP32 module functions as a data processor and data sender via Wi-Fi. This module has analog and digital pins with a 5V input power source. In addition, there is an SD card module that functions as writing data on the SD card. This module uses the SPI interface as a means of communication.

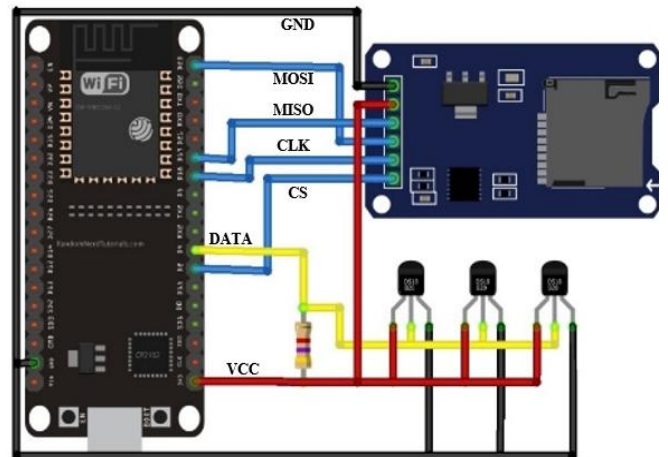

Figure 3. All Circuit blood bank

In this circuit, three DS18B20 sensors are connected to pin D4 on the ESP32. The sensor is a one-wire sensor that has a unique serial code for each sensor. So it is possible to connect on the same pin. The micro SD Card module is connected to the ESP32 via pins GPIO5 – Cs; GPIO23 – MOSI; GPIO18 – CLK; GPIO19 – MISO.

III. Result

A. Modul Design

FIGURE 4 shows the results of the module design that has been made. This simple design is equipped with a Micro SD Card slot, a sensor terminal, and 3 DS18B20 sensors. all these components are processed by ESP32 as a data processor. Figure 5 displays the user interface on Android App (BLYNK).



Figure 4. Module Design



Figure 5. User Interface on Android App (BLYNK)

B. Result Of Measurement

TABLE 1 to analyze and interpret the data, you could use the 60 temperature readings obtained during this first hour. You may calculate various statistical measures such as the mean, median, standard deviation, minimum, and maximum temperature values during this time frame. For example, if we have the following temperature readings (in Celsius) recorded at each minute:

- 8:16 - 23.5°C
- 8:17 - 23.7°C
- 8:18 - 23.8°C
- ...
- 8:59 - 24.1°C
- 9:00 - 24.0°C
- 9:01 - 24.2°C

You would calculate the mean by adding all 60 temperature values and dividing by 60. Similarly, you can find the median by arranging the data in ascending order and selecting the middle value (or the average of the two middle values if the data set has an even number of observations). The standard deviation would help you understand the variability of the temperatures within that hour. Additionally, you could create a line chart or time series plot to visualize the temperature changes throughout the first hour of data collection. This graph would show how the temperature fluctuates over time and if there are any noticeable trends or patterns. Analyzing the first hour's data will provide you with an initial understanding of the temperature distribution within the Blood Bank. However, to have a comprehensive assessment, it's essential to extend the analysis to cover the entire 24-hour data collection period, as different times of the day may present varying temperature patterns. This complete analysis will offer valuable insights for temperature control and management in the Blood Bank to ensure the quality and safety of blood products throughout the day.

TABLE 1.

Blood bank temperature measurement for the first 1 hour

Time	Temp 1 (°C)	Temp 2 (°C)	Temp 3 (°C)
8:17:16	4.5	2.5	3
8:18:16	4.5	2.5	3
8:19:16	4	2.5	2.5
8:20:16	4	2.5	2.5
8:21:16	4	2	2.5
8:22:16	4	2	2.5

8:23:16	4	2	2.5
8:24:16	4	2	2.5
8:25:16	3.5	2	2.5
8:26:16	4	2	2.5
8:27:16	3.5	2	2.5
8:28:16	3.5	2	2.5
8:29:16	3.5	2	2.5
8:30:16	3.5	2	2.5
8:31:16	3.5	2	2
8:32:16	3.5	2	2.5
8:33:16	3.5	2	2.5
8:34:16	3.5	2	2.5
8:35:16	3.5	2	2.5
8:36:16	3.5	2	2.5
8:37:16	3.5	2	2.5
8:38:16	3.5	2	2.5
8:39:16	3.5	2.5	2.5
8:40:16	3.5	2.5	2.5
8:41:16	3.5	2.5	2.5
8:42:16	3.5	2	2.5
8:43:16	3.5	2	2.5
8:44:16	3.5	2	2.5
8:45:16	3.5	2	2
8:46:16	3.5	2	2
8:47:16	3.5	2	2
8:48:16	3	2	2
8:49:16	3	2	2
8:50:16	3	2	2
8:51:16	3	2	2
8:52:16	3	2	2
8:53:16	3	2	2
8:54:16	3	2	2
8:55:16	3	2	2
8:56:16	3	2	2
8:57:16	3	2	2
8:58:16	3	2	2
8:59:16	3.5	2	2.5
9:00:16	3.5	2	2.5
9:01:16	3.5	2	2.5
9:02:16	3.5	2	2.5
9:03:16	3	2	2.5
9:04:16	3	2	2
9:05:16	3	2	2
9:06:16	3	2	2
9:07:16	3	2	2
9:08:16	3	2	2
9:09:16	3	2	2
9:10:16	3	2	2
9:11:16	3	2	2
9:12:16	3	2	2
9:13:16	3	2	2
9:14:16	3	2	2
9:15:16	3	2	2
9:16:16	3	2	2.5

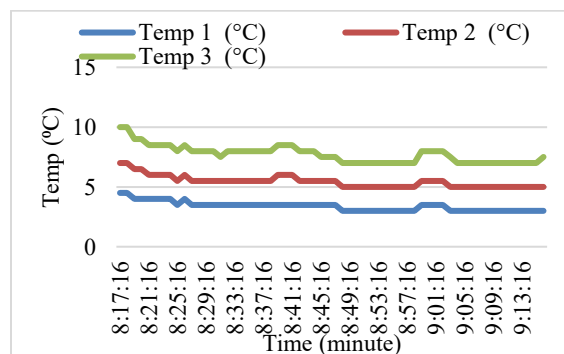

Figure 6. Temperature Measurement Results of the Whole Blood Bank Rack

From these data. it can be seen the difference in temperature for each placement of the sensor. Temperature variable 1 has the highest value of 4.5°C. While the lowest value of 2°C is at temperature 2 and temperature 3 which is explained in the temperature measurement graph FIGURE 6. The difference is the hot point and cold point on the Blood Bank. which are 4.5°C and 2°C. respectively. In TABLE 2 it can be seen that the various variables have differences from each part of the shelf. The upper-temperature variable as much as 1440 data has the lowest value of 3.0 and the highest value of 4.5 with an average value of 3.03 and a standard deviation (level of data distribution) of 0.14.

Table 2. Descriptive Test

Rack Temp	N	Mean	Std. Dev	95% Confidence Interval for Mean		Mini mum	Maxi mum
				Lower Bound	Upper Bound		
				Top	1440		
Center	1440	2.06	0.16	2.05	2.07	2.00	2.50
Bottom	1440	2.16	0.23	2.15	2.17	2.00	3.00
Total	4320	2.42	0.47	2.40	2.43	2.00	4.50

The temperature variable in the middle of 1440 data has the lowest value of 2.0 and the highest value of 2.5 with an average value of 2.06 and a standard deviation (level of data distribution) of 0.16. The lower temperature variable as much as 1440 data has the lowest value of 2.0 and the highest value of 3.0 with an average value of 2.42 and a standard deviation (level of data distribution) of 0.47. So of these variables. with a total of 430. the lowest value is 2.0 and the highest value is 4.5 with an average value of 2.42 and a standard deviation of 0.47.

Table 3. Homogeneity Test

	Levene Statistic	df1	df2	Sig.
Suhu	719.15	2	4317	.000

The homogeneity test is used to determine whether some of the population variances are the same or not. This test was carried out as a prerequisite in the analysis of the independent sample t-test and ANOVA. The underlying assumption in the analysis of variance (ANOVA) is that the variances of the population are the same. The similarity test of two variants is used to test whether the distribution of the data is homogeneous or not. by comparing the two variances. If two or more data groups have the same variance. the homogeneity test does not need to be done again because the data is considered homogeneous. A homogeneity test can be done if the data group is in a normal distribution. Homogeneity tests were conducted to show that the differences that occurred in parametric statistical T-Tests and Anova occurred as a result of differences between groups. not as a result of differences within groups.

The homogeneity of variance test is very necessary before comparing two or more groups. so that the

differences are not caused by differences in the basic data (the groups being compared are not homogeneous).

Based on TABLE 3 Homogeneity test has been carried out above. The Levene Statistic number is obtained. with the main objective of knowing the difference between two groups of data with a different variance of 719.15 with the results of the calculation of the test showing a significance or probability (Sig) of 0.000. The criteria in the homogeneity test are if the significance value is > 0.05 then the data is homogeneous. and if the significance value is < 0.05 then the data is not homogeneous. Because the significance value of 0.000 is smaller than 0.05. it can be concluded that the temperature variance in the three parts of the shelf being compared is not the same or not homogeneous. Because the data variances are not the same. the next test is the Kruskal Wallis Non-Parametric test.

Table 4. Kruskal Wallis Non-Parametric Test

Parameters	Temp
Chi-Square	3534.91
df	2
Asymp. Sig.	.000

The Kruskal Wallis test is a non-parametric statistical test that is used to test more than two samples that are independent of each other and the data used are in the form of nominal and ordinal scales. but the Kruskal wallis test can also be used for interval and ratio scale data. for the test of more than two samples on parametric statistics (ANOVA test) when the assumptions on parametric statistics are not met (for example data are not normally distributed and not homogeneous). then another alternative can be used non-parametric statistics. namely the Kruskal wallis test.

Based on TABLE 4 the results of the statistical test above. it can be seen that the Asymp. The sig value is 0.000 < 0.05. Thus, it can be concluded that H0 is rejected and Ha is accepted. which means there is a real (significant) difference between the temperatures in each part of the shelf. Thus. it can also be said that the temperature of each part of the shelf is not the same or different.

IV. Discussion

The difference in temperature distribution is also influenced by the pattern of using the Blood bank by the user himself. The majority of the use of Blood Banks on each shelf will be separated according to the category of blood stored. whether it is based on blood type. type of blood product. or blood bags that have been and have not been cross-tested. The majority of shelves containing frequently used blood bags will be placed at the top for easy collection. So. the top shelf will most often experience an increase in temperature. From statistical tests on the data taken. it can be interpreted that the three data are not the same or not homogeneous. This is due to differences in

measurement positions. Several factors influence the differences in the data groups, namely the measurement position, the behavior of using the shelf as a storage area, and the position of the cooling source.

Based on the interpretation that has been taken, there are hot points and cold points. This is very reasonable as long as the value is within a predetermined standard. So, from this point a determination can be made in the use of daily monitoring measuring points. So, it is very precise in monitoring the daily temperature of the measuring point used, namely the hot spot at the top of the Blood Bank shelf. In this study, there are several differences when compared with the research references used. Previous research is using a public refrigerator or refrigerator to store reagents. In addition, Yu Zhang carried out the design and implementation of a wireless temperature measurement system. The system is intended for applications that require wireless data collection and monitoring, however, what distinguishes the system made is that it uses NRF9E5 and DS18B20 components. The system is used for temperature and displayed on a computer and can store temperature data[22]. Meanwhile this study uses a Blood Bank as a place to store blood products in the Blood Donation Unit of the Indonesian Red Cross Surabaya City. This research also has drawbacks like research in general, which requires a stable internet connection and sometimes the server on BLYNK decreases even though the connection is stable. In line with the existing shortcomings, the advantage of this research is that practitioners can access temperature monitoring anytime and anywhere. For the Indonesian Red Cross Surabaya Blood Donation Unit, the storage area for blood products plays an important role in maintaining the quality of blood products. So that with this research, practitioners at blood banks can be more aware of the quality of blood products stored in blood banks.

The study also mentions some limitations and weaknesses of the research. Here they are Internet Connection Dependency: One limitation of the study is the requirement for a stable internet connection to access and monitor temperature data. In settings where internet connectivity is unreliable or limited, this dependence may hinder real-time monitoring and data collection. BLYNK Server Performance: The study utilizes the BLYNK platform for data visualization and storage. However, it is mentioned that the BLYNK server's performance can sometimes decrease, even with a stable internet connection. This may result in delays or inaccuracies in data retrieval and analysis. Limited Comparison with Previous Studies: While the study distinguishes itself from previous research that used public refrigerators or different temperature measurement systems, it does not provide a comprehensive comparison with those studies. A more thorough comparison could strengthen the research's

unique contributions and better highlight its advantages.

V. Conclusion

The objective of this study is to examine the temperature distribution in cold storage at the Surabaya Blood Donation Unit of the Indonesian Red Cross. It can be said that this study's use of the ESP32 module, the DS18B20 temperature sensor, and a micro-SD Card for data storage allowed it to be completed successfully. Because the ESP32 module has a capability that allows it to connect to the internet network via a Wi-Fi connection, temperature monitoring can be done at any time. This feature makes the use of the ESP32 module quite good. In light of this, real-time temperature monitoring at the blood bank is seen to be appropriate for temperature measurement devices that use electronic components. Additionally, this research demonstrates that the Blood Bank's temperature dispersion at Red Cross of Indonesia's Blood Transfusion Unit Surabaya City has temperatures about 3°C. According to a blood bank's temperature distribution investigation, each shelf had notable variations. The measuring position is a factor that affects these discrepancies, the way the shelf is being used as a storage space and where the cooling source is located. The author's module still has flaws as a result of many reasons. The NodeMCU module, which is more reliable at relaying data to the IoT server than the ESP32 one, is suggested as a possible development option.

References

- [1] C. G. Koch *et al.*, "Real Age: Red Blood Cell Aging During Storage," *Ann. Thorac. Surg.*, vol. 107, no. 3, pp. 973–980, 2019, doi: 10.1016/j.athoracsur.2018.08.073.
- [2] N. N. Mahzan, A. M. Omar, S. Z. Mohammad Noor, and M. Z. Mohd Rodzi, "Design of data logger with multiple SD cards," *CEAT 2013 - 2013 IEEE Conf. Clean Energy Technol.*, pp. 175–180, 2013, doi: 10.1109/CEAT.2013.6775621.
- [3] C. M. Vancea and L. Viman, "Wireless data logger for thermal validation systems," *2011 IEEE 17th Int. Symp. Des. Technol. Electron. Packag. SIITME 2011 - Conf. Proc.*, pp. 295–298, 2011, doi: 10.1109/SIITME.2011.6102739.
- [4] Z. Lu, J. Li, and Z. Yao, "The reading/writing SD card system based on FPGA," *Proc. - 2010 1st Int. Conf. Pervasive Comput. Signal Process. Appl. PCSPA 2010*, pp. 419–422, 2010, doi: 10.1109/PCSPA.2010.107.
- [5] K. Y. Chen and Y. C. Shaw, "Applying back propagation network to cold chain temperature monitoring," *Adv. Eng. Informatics*, vol. 25, no. 1, pp. 11–22, 2011, doi: 10.1016/j.aei.2010.05.003.
- [6] K. Umamaheswari, M. Susneha, and B. S. Kala, "IoT based Smart Cold Storage System for Efficient Stock Management," *Proc. 2020 IEEE Int. Conf. Commun. Signal Process. ICCSP 2020*, pp. 51–55, 2020, doi: 10.1109/ICCSP48568.2020.9182426.
- [7] W. J. Liao *et al.*, "Sensor integrated antenna design for applications in cold chain logistic services," *IEEE Trans. Antennas Propag.*, vol. 63, no. 2, pp. 727–735, 2015, doi: 10.1109/TAP.2014.2384048.
- [8] J. M. Belman-Flores and A. Gallegos-Muñoz, "Analysis of the flow and temperature distribution inside the compartment of a small refrigerator," *Appl. Therm. Eng.*, vol. 106, pp. 743–752, 2016, doi: 10.1016/j.applthermaleng.2016.06.065.
- [9] V. C. Falcón, Y. V. V. Porras, C. M. G. Altamirano, and U.

- Kartoglu, "A vaccine cold chain temperature monitoring study in the United Mexican States," *Vaccine*, vol. 38, no. 33, pp. 5202–5211, 2020, doi: 10.1016/j.vaccine.2020.06.014.
- [10] S. Umchid, P. Samae, S. Sangkarak, and T. Wangkram, "Design and Development of a Temperature Controlled Blood Bank Transport Cooler," *BMEiCON 2019 - 12th Biomed. Eng. Int. Conf.*, pp. 0–3, 2019, doi: 10.1109/BMEiCON47515.2019.8990203.
- [11] L. J. Hui, F. K. C. Harun, Y. Yusof, and N. M. Safri, "WIRELESS temperature monitoring system for blood bank using Zigbee," *J. Teknol. (Sciences Eng.*, vol. 61, no. 2 SUPPL, pp. 93–98, 2013, doi: 10.11113/jt.v61.1642.
- [12] V. K. Gupta, A. Chaudhuri, and M. K. Tiwari, "Modeling for deployment of digital technologies in the cold chain," *IFAC-PapersOnLine*, vol. 52, no. 13, pp. 1192–1197, 2019, doi: 10.1016/j.ifacol.2019.11.360.
- [13] V. Garrido, I. García-Jalón, and A. I. Vitas, "Temperature distribution in Spanish domestic refrigerators and its effect on *Listeria monocytogenes* growth in sliced ready-to-eat ham," *Food Control*, vol. 21, no. 6, pp. 896–901, 2010, doi: 10.1016/j.foodcont.2009.12.007.
- [14] S. Kiruthika, P. Sakthi, M. Kaviya, and S. Vishnupriya, "Blood Bank Monitoring and Blood Identification System Using IoT Device," vol. 25, no. 6, p. 192, 2021, [Online]. Available: <http://annalsofscsb.ro>
- [15] R. D. Ismail, H. A. Hussein, M. M. Salih, M. A. Ahmed, Q. A. Hameed, and M. B. Omar, "The Use of Web Technology and IoT to Contribute to the Management of Blood Banks in Developing Countries," *Appl. Syst. Innov.*, vol. 5, no. 5, 2022, doi: 10.3390/asi5050090.
- [16] Ramesh Saha, S. Biswas, S. Sarmah, S. Karmakar, and P. Das, "A Working Prototype Using DS18B20 Temperature Sensor and Arduino for Health Monitoring," *SN Comput. Sci.*, vol. 2, no. 1, pp. 1–21, 2021, doi: 10.1007/s42979-020-00434-2.
- [17] L. Balasenthilmurugan and A. Julian, "Design and implementation of Automated Blood Bank using embedded systems," *ICIIECS 2015 - 2015 IEEE Int. Conf. Innov. Information, Embed. Commun. Syst.*, pp. 0–5, 2015, doi: 10.1109/ICIIECS.2015.7193102.
- [18] X. Wang and S. Li, "Multipoint temperature measurement system of hot pack based on DS18B20," *Proc. - 2010 WASE Int. Conf. Inf. Eng. ICIE 2010*, vol. 1, pp. 26–29, 2010, doi: 10.1109/ICIE.2010.14.
- [19] A. Maier, A. Sharp, and V. Yuriy, "Comparative Analysis and Practical Implementation of the ESP32 Microcontroller Module for the Internet of Things," *2017 Internet Technol. Appl.*, pp. 143–148, 2014.
- [20] D. Mayasari, "Temperature Distribution Monitoring on Blood Bank Chamber Using Android Application on Mobile Phone," vol. 16, no. 1, pp. 14–20, 2023.
- [21] M. Babiuch, P. Foltynnek, and P. Smutny, "Using the ESP32 microcontroller for data processing," *Proc. 2019 20th Int. Carpathian Control Conf. ICCO 2019*, pp. 1–6, 2019, doi: 10.1109/CarpathianCC.2019.8765944.
- [22] Y. Zhang, Z. S. Wang, and J. Li, "Design a wireless temperature measurement system based on NRF9E5 and DS18B20," *2010 Int. Conf. Meas. Technol. Mechatronics Autom. ICMTMA 2010*, vol. 1, pp. 910–913, 2010, doi: 10.1109/ICMTMA.2010.632.