

Manuscript received August 03, 2022; revised September 01, 2022; accepted November 20, 2022; date of publication November 25, 2022  
Digital Object Identifier (DOI): <https://doi.org/10.35882/ijeemi.v4i4.247>

Copyright © 2022 by the authors. This work is an open-access article and licensed under a Creative Commons Attribution-ShareAlike 4.0 International License ([CC BY-SA 4.0](https://creativecommons.org/licenses/by-sa/4.0/))

**How to cite:** Torib Hamzah, Endang Dian Setioningsih, Sumber, and Nazila Ragimova, "Electronic Stethoscope Equipped with IoT-based Remote Monitoring to Detect Disease Symptoms", Indonesian Journal of Electronics, Electromedical Engineering, and Medical Informatics, vol. 4, no. 4, pp. 168–173, November. 2022.

# Electronic Stethoscope Equipped with IoT-based Remote Monitoring to Detect Disease Symptoms

Torib Hamzah<sup>1</sup> , Endang Dian Setioningsih<sup>1</sup> , Sumber<sup>1</sup> , and Nazila Ragimova<sup>2</sup> 

<sup>1</sup> Department of Medical Electronics Technology, Poltekkes Kemenkes. Surabaya, Indonesia

<sup>2</sup> Department of Computer engineering, Azerbaijan State Oil and Industry University, Azerbaijan

Corresponding author: Endang Dian Setioningsih (e-mail: [bdian12@poltekkesdepkes-sby.ac.id](mailto:bdian12@poltekkesdepkes-sby.ac.id))

**ABSTRACT** Auscultation is a technique or method most often used by medical personnel in the initial examination of patients. One way to carry out this method is by using a stethoscope. However, this method has its drawbacks because the diagnosis is carried out subjectively and cannot be relied on with the accuracy to diagnose the symptoms of heart defects. Thus, the purpose of this study was to create an IoT system for electronic stethoscopes with BPM value output and make analog filters to eliminate noise interference which was a major obstacle in previous studies. The contribution of this research is to make it easier for medical users to analyze heart rate using an electronic stethoscope while at the same time being able to know the number of BPM automatically that can be monitored remotely because it used IoT system. Furthermore, the method used in this study was by using a mic condenser placed on the patient's chest to detect pressure changes. When the pressure changes, the voltage output value on the condenser mic also changes. In this case, the output from the condenser mic went in and follows the analog signal conditioning circuit. The output signal from the analog signal conditioning further entered the programmed microcontroller. Furthermore, based on the measurement conducted, the error value of BPM was obtained from the five respondents. In this case, the error value generated from respondent 1 was 0.33 BPM, the error value obtained from respondent 2 was 0.67 BPM, the error value obtained from respondent 3 was 0.5 BPM, the error value obtained from respondent 4 was 0.67, and the error value obtained from respondent 5 was 0.67 BPM. Meanwhile, the results of the statistical test obtained P-Value of more than 0.05, indicating that the resulting value did not have a significant difference and could be used for medical purposes. Therefore, current research easier makes it easier for doctors to analyze and diagnose symptoms of heart defects because this system is equipped with the detection of disease symptoms.

**INDEX TERMS** BPM, Stethoscope electronic, Internet of Think

## I. Introduction

Auscultation is a technique or method most often used by medical personnel in the initial examination of patients. One way to carry out this method is by using a tool called a stethoscope. A stethoscope is a simple acoustic medical device that serves to diagnose sounds in the human body. Medical personnel often use aqueous stethoscope to check the sound of the heart. One sound that can be detected is a sound associated with the activity of the heart pumping. Such voices indicate heart rate and heart rhythm. Therefore, this sound is useful for providing information about the effectiveness of the pumping activity of the heart and liver valves. To date, the clinical instrument used to detect cardiac sounds is an acoustic stethoscope [1]. The rapid development of medical equipment technology in the community has made the health care system better and more professional. Public

awareness of the importance of health has caused early self-examination to become increasingly popular [2]. Many techniques have been developed to make the initial diagnosis faster and more accurate. One of the diseases that occurs a lot in society is heart disease. Heart disease ranks first as the cause of death causing more than 30% of the world's total population in 2008 [3].

On the other hand, stethoscope is a simple tool to detect the sound auscultation of the Heart and lungs [4]. The tool can find out whether the body condition in a person has symptoms of abnormalities or not. Related to this, the results of the doctor's diagnosis are based on hearing and experience so that error can occur on the diagnosis because of the tool factor or the error factor in humans. In addition, this method also has its drawbacks because the diagnosis is done subjectively and does not have reliable accuracy to

diagnose the symptoms of heart defects as Yi Luo conveyed [5]. Indications of heart defects can be surely detected early by using a stethoscope, thus there are several diagnoses and factors that cause heart defects [3][4][8][9]. Along with the development of stethoscope technology, several researchers have also made development on the tool to help doctors diagnose one of the vital conditions in the human body, since the acoustic stethoscope sound output produced is very low and noisy so it is not suitable if used in noisy conditions [10]. Therefore, electronic stethoscopes have been developed up to recently to overcome these problems as has been done by Sanket Gupta [4]. Electronic stethoscopes are made using a condenser mic sensor to capture heart signals attached to the microcontroller. However, this system causes considerable noise so that further development is needed. Electronic stethoscope is basically used to detect lub-dub sounds or often referred to as S1 in the first heart sound and S2 as the second heart sound [11][12][13].

This system is quite good for detecting the heart sound detection but also has a quite high noise so it is not suitable to be used in noisy environments such as ambulance cars. Daniel A. Kelmenson et al compared the accuracy of electronic stethoscopes and conventional stethoscopes for cardiac sound detection through a survey involving 41 doctors with the results of subjects significantly preferred electronic stethoscopes to diagnose cardiac sounds [16]. This statement can conclude that the use of electronic stethoscope is more efficient than conventional stethoscopes. Furthermore, some other researchers also developed it using various methods, including Ramesha M et al, who made electronic stethoscopes that can be monitored at a long distance using Bluetooth, yet the disadvantage of using this system is the limited distance of data transmission [15]. Many methods have been used to accurately produce the analysis output for the detection of lub-dup on the heart sound on the electronic stethoscope, as discussed by Shuang Leng et al. In this case, S1 and S2 analysis used the continuous wavelet transform (CWT) method that is able to detect the frequency and time simultaneously so it is very accurate to detect S1 and S2 [14]. However, CWT has heavy computation. Sumarna, et al further carried out improvement on the PCG signal for electronic stethoscope by analyzing the signal using fast fourier transform (FFT) and further applied it on the making of reliable instrumentation [13]. In addition, Olga Szymanowska et al, created an electronic stethoscope connected with a Personal Computer (PC) with analyzable sampling and simultaneous monitoring of signals. This method is preferred to conventional stethoscopes, but the noise is still too large so that a pre amplifier and filter are needed to filter out unwanted frequencies [19]. In this case, in order to eliminate noise interference, there are several filters that are recommended by several

researchers including IIR filters, Chebichev, Wavelet, and so on [20][21].

Based on the explanation that has been described in previous studies, the author has not found any remote monitoring for the analysis of heart rate sound signals through the internet of thought (IoT) using the android system. In addition, there is no analysis of the detection of symptoms of heart defects either, which is expected to make it easier for doctors to analyze and monitor signals simultaneously, especially for patients in isolation rooms [22][23]. Therefore, current research was conducted aiming to create an IoT system for electronic stethoscopes with BPM value output and create analog filters to eliminate noise interference which was a major obstacle in previous studies. It is further expected that this research can make it easier for doctors to analyze and diagnose symptoms of heart defects because this system is equipped with the detection of disease symptoms.

## II. Materials and Methods

### A. Experimental Setup

In this study, there were five respondents involved in the trials. In this case, their BPM was read 6 times for the measurement. Measurements were made by attaching the chest piece to the left chest of the respondent and then displaying it on a 16x2 character LCD.

#### 1) Material And Tool

The material used in this study was ESP32 microcontroller, which was used as the system control and for data transmission via the Internet of Think which was further displayed on an android using the Blynk system.

#### 2) Experiment

In this experimental study, a condenser mic was placed on the patient's chest to detect pressure changes. After that, the signal was filtered using an analog signal conditioning circuit. Furthermore, testing was carried out on five respondents and each respondent was measured 6 times. In this case, the analog circuit consists of a pre amplifier circuit and a band pass filter circuit that was a combination of the combined HPF - 20db and LPF -20db circuits. Furthermore, the BPF output was employed as an additional circuit input to increase the reference of the heart sound signal so that there was no negative signal entering the mini system circuit since the mini system cannot detect the negative signal.

### B. The Diagram Block

The condenser mic was placed on the patient's chest to detect the pressure changes. In this case, as the pressure changed, the voltage output value on the condenser mic also changed. The output from the condenser mic was further entered and processed in the analog signal conditioning circuit. The signal output from the analog signal conditioning went into the pre-programmed microcontroller. This microcontroller was used to process the signal on the BPM (beat per minute). In this case, when a cardiac arrest is detected

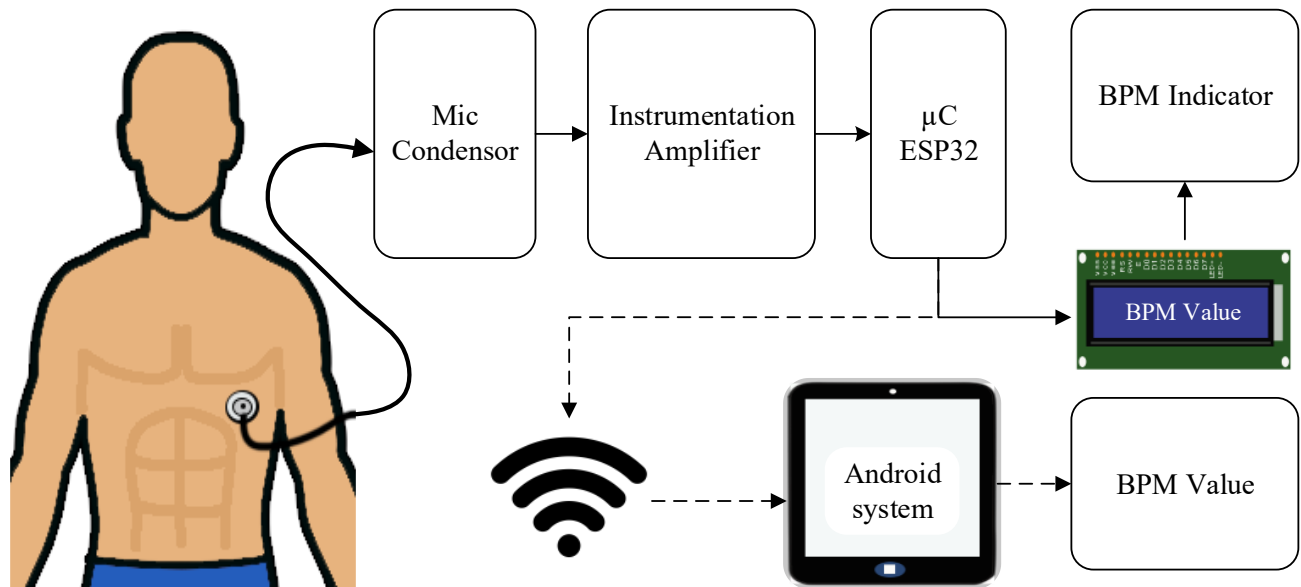

**FIGURE 1.** Block diagram, the signal output from the condenser mic will be filtered using a signal conditioning circuit then processed in the ESP32 microcontroller which will be displayed on the LCD and sent via the blynk application to the android system.

for more than 10 seconds, the microcontroller will send data to the Android via the Wi-Fi network. In addition, when respiration occurs, the respiratory indicators will also light up. These steps are further illustrated in **FIGURE 1**.

### C. The Flowchart

The control program was built based on the flowchart as shown in **FIGURE 2**. Flowchart began with the initialization connection of the microcontroller that was connected to Wi-Fi. The data received by Wi-Fi on Android was then processed on a microcontroller which later was displayed the BPM (beat per minute) value. If the heart ticking stops, there will be a notification on the Android system which functions as a warning for the user so that action is taken immediately.

### D. The Analog Circuit

The detection of the heart sound was done by placing a condenser mic on the chestpiece. The condenser mic further converted the vibration received during the detection of the sound into an electrical signal. In the pre-amp circuit, there was a signal gain process from the condenser mic but there was still interference or noise as well (**APPENDIX**). Therefore, a series of band pass filters were made to reduce the noise, from a combination of the HPF -20db and LPF -20db (**APPENDIX**) circuits. Before entering the mini-circuit system, the heart sound signal that has been strengthened and filtered, still need an additional circuit in the form of an adder. This adder serves to raise the reference of the heart sound signal so that no negative signal enters the mini system circuit because the mini system cannot detect the negative signal. The band pass filter was designed for the cut off frequency of 0.05 to 100 Hz. The gain and the cut off value were further

calculated using **EQUATION 1** and **EQUATION 2**, respectively. In this study, the gain was 101 x [24].

$$Gain = 1 + \frac{2R_f}{R} \quad (1)$$

Where  $R_f$  is the feedback gain,  $R_6$  is the divider resistance, and the Gain is the amplification of the circuit  $f_c = 1/2\pi RC$

Where  $R$  is the resistance value,  $C$  is the capacitance value, and  $f_c$  indicated the cut off frequency

### E. Microcontroller And Mechanical Design

The photograph of the analogue and digital part of the Holter PCG was shown (**APPENDIX**), respectively. The analogue part consisted of three of TL084 (OP-AMP), where each unit was composed of four OP-AMP. There was also some variable resistors (multiturn 10k) for gain and offset adjustment. Furthermore, the digital part consisted of the Arduino ESP 32 microcontroller which is the main board of PCG device, and LCD 6X12 in which to displayed the BPM data in real time (**APPENDIX**).

### III. Result

A whole circuit has been created, where the circuit consisted of a pre-amp circuit, a 40 db HPF and LPF circuit, and an adder circuit. The heart sound signal captured by the condenser mic was first entered the capacitor that functions as a DC coupling and then was corroborated using a non-inverting amplifier circuit. Next, it was filtered to remove the noise. The output of the filter circuit then entered a multiturn to set the reference value of the signal. After the stethoscope signal has been raised by the adder circuit, the signal entered the ESP32 microcontroller which later was processed and displayed on the 16x2 character LCD. Furthermore, the data were sent to the Blynk android application using a Wi-Fi network to make it easier to retrieve the data (**APPENDIX**).

1) Measurement Results In Respondents

In the measurements of this study, three comparisons of BPM reading measurements were carried out, including readings on the Module that had been, readings on the Oximeter, and readings sent through the blynk application displayed on android. In addition, the BPM measurements were carried out on five respondents with each respondent taking 6 measurements described in TABLE 1.

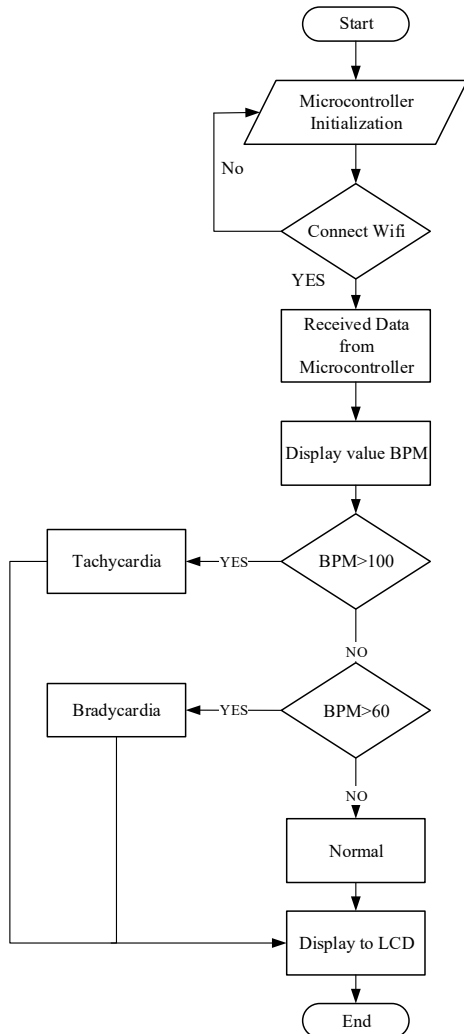

FIGURE 2. The flow chart of the android program. The android program is carried out when the BPM value shows more than 100. Then, the results of Tachycardia are displayed on the LCD screen. However, it is normal if the BPM value is more than 60. In addition, if the value obtained is less than 60 then bradycardia results are displayed

TABLE I.

BPM measurement on 5 respondents for 6 measurements, respectively.

	Average Readings on Respondents (BPM)				
Display LCD	85.66	77.16	84.66	94	85
Oximeter	85.33	77.83	85.16	93.33	85.66
Display Blynk	85.66	77.16	84.66	94	85
Error (BPM)	0.333	0.67	0.5	0.67	0.67

Based on the explanation of TABLE I, the mean value was obtained from the measurement of bpm values from 5 respondents. In this case, the error value obtained from respondent 1 was 0.33 BPM, the error value obtained from respondent 2 was 0.67 BPM, the error value obtained from respondent 3 was 0.5 BPM, the error value obtained from respondent 4 was 0.67, and the error value obtained from respondent 5 was 0.67 BPM. The results of TABLE I is also explained on FIGURE 3.

Based on the FIGURE 3, it is explained that the bar chart per respondent consisted of readings on the LCD screen, Oximeter, and Blynk screen. In addition, there was also an error bar that showed the value of the reading error in each measurement. Measurements were taken for 5 respondents, in which measurement on each respondent was taken 6 times.

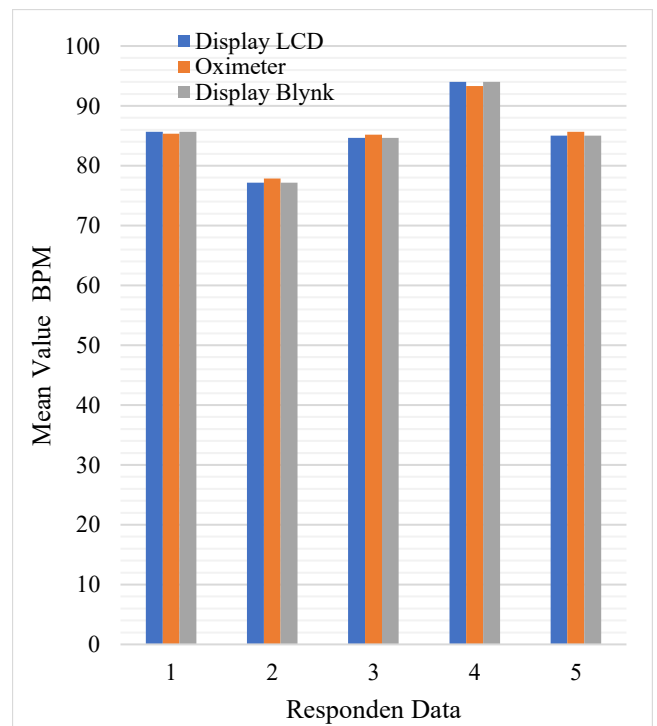

FIGURE 3. There are 3 BPM reading diagrams in each respondent, namely readings on LCD Displays, Oximeters and Blynk Displays

2) Statistical Test Result Using T-Test

In order to find out whether there were significant differences in the measurements of each display, namely the LCD display, Oximeter, and blynk system reading display displayed on an Android cellphone, a T-Test statistic test was carried out using the P-Value of more than 0.05 as shown in TABLE 2. Based on the results of the T-Anova test as described in TABLE 2 obtained from the measurements of each respondent with three output parameters, namely those displayed on the LCD display, Oximeter, and blink display on Android, the mean value obtained was 85 BPM ± 2.59 and the P-Value obtained was 0.99863, indicating that the P-Value is more than 0.05.

TABLE 2

Anova statistical test using an alpha value of 0.05 with each 5 respondents displayed on 3 outputs, namely LCD display, oximeter, and android display

DESCRIPTION	Alpha					0.05			
	Group	Count	Sum	Mean	Variance	SS	Std Err	Lower	Upper
Display LCD		5	426.5	85.30002	35.61653	142.4661	2.598823	79.63767	90.96237
Oximeter		5	427.3	85.46666	30.075	120.3	2.598823	79.80431	91.12901
Display Blynk									
Android		5	426.5	85.30001	35.61666	142.4666	2.598823	79.63766	90.96236
ANOVA									
Sources	SS	df	MS	F	P value	F crit	RMSSE	Omega Sq	
Between Groups	0.093	2	0.046285	0.001371	<b>0.99863</b>	3.885294	0.016557	-0.1536	
Within Groups	405.2	12	33.76939						
Total	405.3	14	28.95181						

#### IV. Discussion

After the data collection, the measurement results of each respondent were produced, where each 5 respondents obtained a mean value of BPM readings from 3 display outputs, namely the LCD Display tool made, Oximeter, and blynk display. In this case, the error value obtained from respondent 1 was 0.33 BPM, the error value obtained from respondent 2 was 0.67 BPM, the error value obtained from respondent 3 was 0.5 BPM, the error value obtained from respondent 4 was 0.67, and the error value obtained from respondent 5 was 0.67 BPM. Based on the results of the T-Anova test, the P-Value value obtained was 0.99863, indicating that the P-Value was more than 0.05, so there was no significant difference between them so that the tool can be used for medical purposes which was obtained from the measurement of each respondent with 3 output parameters. In addition, the resulting value showed no significant difference either and can be used for medical purposes.

Ramesha M et al, have designed an electronic stethoscope that can be monitored at a distance using bluetooth. The disadvantage of using this system is the limited distance of data transmission [15]. Furthermore, Olga Szymanowska et al, created an electronic stethoscope connected with a Personal Computer (PC) with analyzable sampling and simultaneous monitoring of signals. This method is superior to conventional stethoscopes, but the noise caused was still too large so that a pre amplifier and filter were needed to filter out unwanted frequencies [14].

This module was designed by carrying out monitoring BPM via Bluetooth that was displayed on the blynk platform on Android. Therefore, the contribution to this research can make it easier for users to monitor the BPM. Meanwhile, the downside of this study is the use of blynk, since it needs token before being used.

Furthermore, the limitation in this research is that the filter used was still an analog filter so there is still noise interference and the IoT application used still needs to be developed further.

#### V. Conclusion

The purpose of this study is to create an IoT system for electronic stethoscopes with BPM value output and

make analog filters to eliminate noise interference which was a major obstacle in previous studies. The measurement results from 5 respondents obtained the highest error value of 0.67 BPM, indicating that this value is still within the set standard value, hence this tool can be used for medical purposes. Furthermore, based on the results of the T-Anova test, a P-Value of 0.99863 was obtained means that the P-Value > 0.05, so there is no significant difference between them so that the tool can be used for medical purposes which was obtained from the measurement of each respondent with 3 output parameters. In addition, the resulting value also shows that there is no significant difference and can be used for medical purposes. For further research, the author will develop an IoT system with a better system than applications other than Blynk, because the blink application still has a drawback, where each account must have tokens.

#### References

- [1] I. D. Gede and H. Wisana, "Design Electronic Stethoscope for Cardiac Auscultation analyzed using Wavelet Decomposition," *Int. J. Comput. Networks Commun. Secur.*, vol. 1, no. 2013, pp. 310–315, 2013, doi: 10.47277/ijcncs/1(7)4.
- [2] G. D. Buckberg, N. C. Nanda, C. Nguyen, and M. J. Kocica, "What is the heart? Anatomy, function, pathophysiology, and misconceptions," *J. Cardiovasc. Dev. Dis.*, vol. 5, no. 2, 2018, doi: 10.3390/jcdd5020033.
- [3] C. K. Lao et al., "Portable Heart Rate Detector Based on Photoplethysmography with Android Programmable Devices for Ubiquitous Health Monitoring System," *Int. J. Adv. Telecommun. Electrotech. Signals Syst.*, vol. 2, no. 1, 2012, doi: 10.11601/ijates.v2i1.22.
- [4] S. Pandey, "Low Noise Electronic Stethoscope," vol. 10, no. 14, pp. 52–58, 2016.
- [5] Y. Luo, "Portable Bluetooth visual electrical stethoscope research," *Int. Conf. Commun. Technol. Proceedings, ICCT*, pp. 634–636, 2008, doi: 10.1109/ICCT.2008.4716174.
- [6] M. C. Todaro, L. Oreto, R. Qamar, T. E. Paterick, S. Carerj, and B. K. Khandheria, "Review: Cardiology: State of the heart," *Int. J. Cardiol.*, vol. 168, no. 2, pp. 680–687, 2013, doi: 10.1016/j.ijcard.2013.03.133.
- [7] V. Mahadevan, "Anatomy of the heart," *Surg. (United Kingdom)*, vol. 36, no. 2, pp. 43–47, 2018, doi: 10.1016/j.mpsur.2017.11.010.
- [8] A. Groenewegen, F. H. Rutten, A. Mosterd, and A. W. Hoes, "Epidemiology of heart failure," *Eur. J. Heart Fail.*, vol. 22, no. 8, pp. 1342–1356, 2020, doi: 10.1002/ehf.1858.
- [9] R. McCraty and F. Shaffer, "Heart rate variability: New perspectives on physiological mechanisms, assessment of self-regulatory capacity, and health risk," *Glob. Adv. Heal. Med.*, vol. 4, no. 1, pp. 46–61, 2015, doi:

10.7453/gahmj.2014.073.

[10] A. Kakati, R. Gogoi, J. Singha, and J. Laskar, "an User Friendly Electronic Stethoscope for Heart Rate Monitoring," *J. Appl. Fundam. Sci. JAFS/ISSN*, vol. 1, no. 2, p. 233, 2015.

[11] A. B. Kambhampati and B. Ramkumar, "Automatic Detection and Classification of Systolic and Diastolic Profiles of PCG Corrupted Due to Limitations of Electronic Stethoscope Recording," *IEEE Sens. J.*, vol. 21, no. 4, pp. 5292–5302, 2021, doi: 10.1109/JSEN.2020.3028373.

[12] N. Dewangan and R. M. Potdar, "Noise Cancellation Using Adaptive Filter for PCG Signal," vol. 3, no. 4, pp. 38–43, 2014.

[13] Sumarna, J. Astono, A. Purwanto, and D. K. Agustika, "The improvement of phonocardiograph signal (Pcg) representation through the electronic stethoscope," *Int. Conf. Electr. Eng. Comput. Sci. Informatics*, vol. 4, no. September, pp. 145–149, 2017, doi: 10.11591/ieecs.4.1008.

[14] S. Leng, R. S. Tan, K. T. C. Chai, C. Wang, D. Ghista, and L. Zhong, "The electronic stethoscope," *Biomed. Eng. Online*, vol. 14, no. 1, pp. 1–37, 2015, doi: 10.1186/s12938-015-0056-y.

[15] M. Ramesha, V. Dankangowda, K. M. Jeevan, and B. M. Sathisha, "Implementation of IoT Based Wireless Electronic Stethoscope," *MPCIT 2020 - Proc. IEEE 3rd Int. Conf. Multimedia Process. Commun. Inf. Technol.*, pp. 103–106, 2020, doi: 10.1109/MPCIT51588.2020.9350476.

[16] D. A. Kelmenson *et al.*, "Prototype electronic stethoscope vs conventional stethoscope for auscultation of heart sounds," *J. Med. Eng. Technol.*, vol. 38, no. 6, pp. 307–310, 2014, doi: 10.3109/03091902.2014.921253.

[17] A. S. Iskandar, A. S. Prihatmanto, and S. Rangkuti, "Design of electronic stethoscope to prevent error analysis of heart patients circumstances," *Proc. 2014 IEEE 4th Int. Conf. Syst. Eng. Technol. ICSET 2014*, pp. 1–4, 2014, doi: 10.1109/ICSEngT.2014.7111789.

[18] A. Jain, R. Sahu, A. Jain, T. Gaumnitz, P. Sethi, and R. Lodha, "Development and validation of a low-cost electronic stethoscope: DIY digital stethoscope," *BMJ Innov.*, vol. 7, no. 4, pp. 609–613, 2021, doi: 10.1136/bmjinnov-2021-000715.

[19] O. Szymanowska, B. Zagrodny, M. Ludwicki, and J. Awrejcewicz, "Development of an electronic stethoscope," *Adv. Intell. Syst. Comput.*, vol. 414, pp. 189–204, 2016, doi: 10.1007/978-3-319-26886-6\_12.

[20] A. M. Maghfiroh *et al.*, "State-of-the-Art Method Denoising Electrocardiogram Signal: A Review," no. 56, pp. 301–310, 2022, doi: 10.1007/978-981-19-1804-9\_24.

[21] M. Hookari, S. Roshani, and S. Roshani, "Design of a low pass filter using rhombus-shaped resonators with an analytical LC equivalent circuit," *Turkish J. Electr. Eng. Comput. Sci.*, vol. 28, no. 2, pp. 865–874, 2020, doi: 10.3906/elk-1905-153.

[22] D. K. Degbedzui, M. Tetteh, E. E. Kaufmann, and G. A. Mills, "BLUETOOTH-BASED WIRELESS DIGITAL STETHOSCOPE with MOBILE INTEGRATION," *Biomed. Eng. - Appl. Basis Commun.*, vol. 30, no. 3, pp. 1–15, 2018, doi: 10.4015/S1016237218500102.

[23] G. A. Mills, "Wireless digital stethoscope using bluetooth technology," *Int. J. Eng. Sci. Technol.*, vol. 4, no. 08, pp. 3961–3969, 2012.

[24] M. Oljaca and H. Surtihadi, "Operational amplifier gain stability, Part 1 : AC General System Analysis," *Analog Appl. J. (Texas Instruments Inc.)*, no. 3Q, pp. 23–27, 2010, [Online]. Available: <http://www.ti.com/lit/an/slyt383/slyt383.pdf>.

APPENDIX

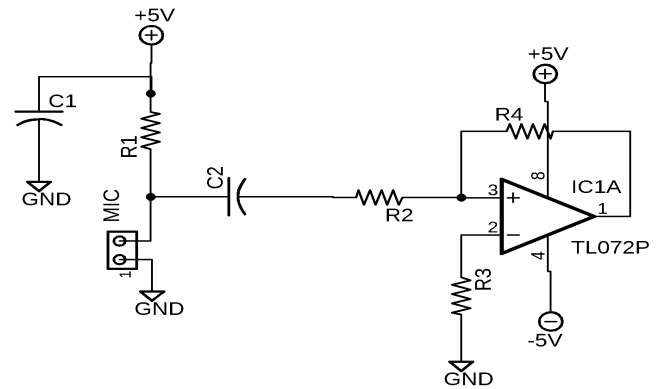

(pre amplifier)

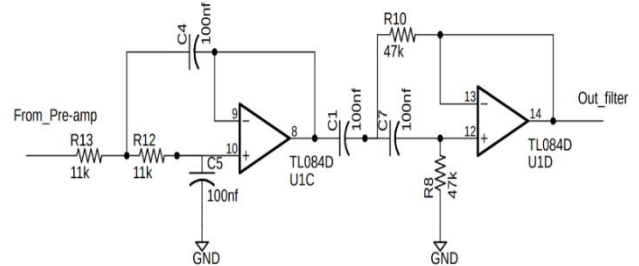

(band pass filter)

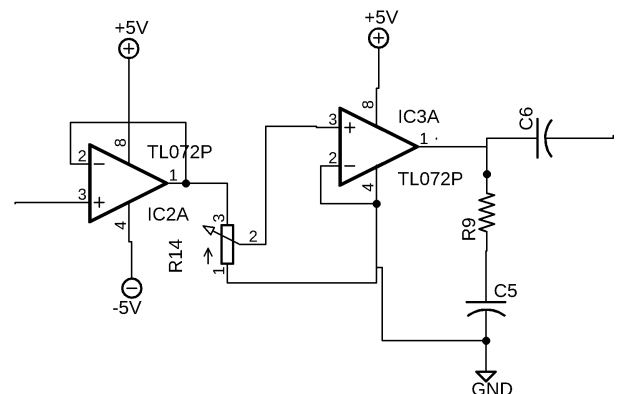

(Adder)

