

## RESEARCH ARTICLE

## OPEN ACCESS

Manuscript received June 03, 2022; revised September 01, 2022; accepted September 01, 2022; date of publication November 28, 2022

Digital Object Identifier (DOI): <https://doi.org/10.35882/ijeemi.v4i4.252>

Copyright © 2022 by the authors. This work is an open-access article and licensed under a Creative Commons Attribution-ShareAlike 4.0 International License ([CC BY-SA 4.0](https://creativecommons.org/licenses/by-sa/4.0/))

**How to cite:** Farid Amrinsani, Levana Forra Wakidi, Made Dwi Pandya Suryanta, and Dessy Tri Wulandari, "Detection of Electromyography Signal using Dry and Disposable Electrodes on the Bicep Muscle While Lifting Weights", Indonesian Journal of Electronics, Electromedical Engineering, and Medical Informatics, vol. 4, no. 4, pp. 282–286, November. 2022.

# Detection of Electromyography Signal using Dry and Disposable Electrodes on the Bicep Muscle While Lifting Weights

Farid Amrinsani<sup>1</sup> , Levana Forra Wakidi<sup>1</sup> , Made Dwi Pandya Suryanta<sup>1</sup>, Dessy Tri Wulandari<sup>1</sup>, and Muhammad Tariq Sadiq<sup>2</sup> 

<sup>1</sup> Department of Electromedical Engineering, Poltekkes Kemenkes Surabaya, Jl. Pucang Jajar Timur No. 10, Surabaya, 60245, Indonesia

<sup>2</sup> School of Architecture, Technology, and Engineering, University of Brighton, United Kingdom

Corresponding author: Levana Forra Wakidi (e-mail: [lep.forra@poltekkesdepkes-sby.ac.id](mailto:lep.forra@poltekkesdepkes-sby.ac.id)).

**ABSTRACT** One of the biosignals used to identify human muscle impulses is electromyography. Electromyographic signals are often used as input and are designed to help people with disabilities or help the healing process after stroke therapy. According to research, this incident has led to the development of various electromyography module sensor designs to meet different purposes. This research was conducted to make two different electromyography module designs and test these modules simultaneously when the biceps lifted a weight of 3Kg. The aim of this study was to compare the use of disposable and dry electrodes from the two electromyographic sensor module designs that were made. using root mean square (RMS) to find out the difference in tension generated when lifting the barbell. each module detects the biceps signal simultaneously. The biceps are part of the upper limb muscles. Based on the findings of this study, both E1 and E2 electromyography modules with disposable electrodes produced data with a p-value of 0.001766368 less than 0.05. while for the t-test of the two Electromyography modules E1 and E2 with dry electrodes it is 0.001766368 which is less than 0.05. Therefore, it can be concluded that there is a significant difference between the E1 and E2 modules. there is an average amplitude difference of 10mV between E1 and E2 modules when using both types of electrodes. and there is a difference in the average amplitude using dry and disposable electrodes of 30mV. The results of this study can be used to provide insight into the detection of electromyography signals, while the two module designs developed can be applied in future studies to detect electromyography.

**INDEX TERMS** Electromyography, Dry Electrode, Disposable Electrode, Root Mean Square.

## I. Introduction

A device called Bio signal is used to find electrical impulses in the body. One of the bio signals employed to identify human muscle impulses is electromyography [1][2][3]. Numerous researchers have been looking at the freshly developed field of electrotherapy to aid those with disabilities or those recovering from post-stroke therapy [4][5][6]. Therefore, numerous electromyography module sensor designs have been resulted as well to support various purposes in line with their study. Since the research projects focused on the outcomes of the classification, several of them also used commercially available tools. In addition, many researchers also worked on the creation of electromyography sensor devices [7][8][9]. In this case, Emma Farago conducted a related study by identifying and recording the electromyography signals from seven different muscles from seven patients to create an electromyography-based model of muscle health for people with elbow trauma. In this case, the electrode placement followed

the SENIAM standards. In addition, the study also employed a commercial wireless myoelectric system to capture and amplify sEMG signals, which were discovered by previous researchers (Trigno Wireless Systems, Delsys Inc., Natick, MA, USA). In this case, the sampling frequency was 1925.93 Hz and the signal had a gain of 300 [10].

In an effort to improve the circuit, J. Antonio undertook research that resulted in the invention of an active electronic electrode by doing utilizing the impedance and filter coupling stages [11]. For the purpose of detecting electromyography signals, several studies have been conducted on electrodes comparison. One of them was done by A Searle et al, who tested electrode impedance, static interference, and motion artifacts to compare three different types of bioelectrodes quantitatively [12][11]. Additionally, C. Pylatiuk et al. investigated comparisons when employing electrodes made of four various polymeric materials [12]. Furthermore, Araceli Guadalupe Santana Rayo and colleagues compared the use of a

disposable electrode with a gel and a dry electrode [13]. Momona Yamagami et al. looked at the acquisition of impedance and sEMG data from clinical and ESS electrodes on eight subjects, where there was no deterioration in signal quality at the electrodes during data collection. Additionally, when thin, flexible electrodes are more effective over the long run, outcomes are also attained [14].

Furthermore, Andre Paiva et al. investigated the impact of fabric construction on electrode performance, in which they discovered that there was a greater acquisition for sEMG when utilizing textile electrodes with noticeable changes in fabric structure [15]. Related to this topic, Yulin Fu et al. further studied the advantages and drawbacks of employing both disposable and dry electrodes, in which when the gel or disposable electrode was used, an electromyography signal can be produced and recorded, yet it was not stable. In addition, the infection can also occur because the gel employed does not match the requirements for signal acquisition. On the other hand, when a dry electrode was used to monitor the bioelectric signal, no infection occurred due to the absence of gel required [16]. Furthermore, through the use of Ag/AgCl electrodes, Marco S. Rodrigues discovered that the signal needed to be intercepted for a considerable amount of time hence a gel was necessary. The research obtained the creation of titanium dry electrodes, which still need to be developed further. In this case, the choice of material affects the type of electrode, whether it can be used to capture sEMG signals, and whether it offers any other advantages [17]. Disposable electrodes that produce skin allergies, movement artifacts, and influence the quality of signal attenuation were further become the subject of research conducted by Xiong Zeng et al. Dry electrodes, however, were preferred since they enhanced the signal quality and held electrodes that may be used for an extended period with good outcomes [18]. Furthermore, Y. Dassonville et al did a research project to record EMG signals, where dry electrodes with good electrical and mechanical contact with the skin were studied. These electrodes are more novel and can compare electrical bioimpedance [19]. R. G. Scalisi further researched HD electrodes that can generate electricity with good resolution, resistance, and electrode contact impedance with the skin as determined by comparison when using commercial electrodes [20]. By creating real-time movement, Asma M. Naim is working on sEMG signals that are used for a long period [21]. Pascal Laferriere researched dry electrodes with electromyography signal recording sensitivity similar to Ag/AgCl electrodes that use gels [22]. In addition, Kunal et al. investigated methods to manage the rehabilitation device's functionality. The creation of a wireless electromyography control system was further discussed in this paper, where a little wheelchair replica was also used to test the suggested control mechanism. Furthermore, Kunal and

colleagues investigated ways to regulate the rehabilitation device's functionality. This paper discussed the creation of a wireless electromyography control system. The Texas Instruments IC AD620, disposable Ag/AgCl electrodes with connected probes, and the Arduino UNO microcontroller were all used in amplifier instrumentation. In this case, in order to evaluate the suggested control system, a scale model wheelchair was used [23]. Wireless surface electromyography and a non-invasive preamplifier were further created by S.S. Lee et al. In this case, the researchers concentrated on creating a wireless electromyography preamplifier using three electrodes, including Bluetooth module and A/D converter for wireless communication. This system also used 1.024 Hz as its sampling frequency. According to the researchers, the electromyography system he developed was somewhat superior than those offered commercially. Ag/AgCl electrodes were applied in the research. The designed system also has an inbuilt high-pass filter with a cutoff frequency of 10 Hz, a low-pass filter with a cutoff frequency of 1,000 Hz and a 110 dB amplifier, and Bluetooth baud rate set to 115200bps [24]. In another study, HAL was created and developed by Teena George et al. using electromyogram (EMG) signals. In this study, the total of all motor unit action potentials (MUAPs) in the pickup region was obtained using a surface electrode. To further their investigation, the researcher also used a commercial bio signal detecting system, the Biopac MP 100 with an electromyography amplifier [25]. Another previous study then also conducted by Fariz Ali and colleagues focusing on muscle signals to control a 4-dof hand robot. Because the Myoware muscle sensor could assess muscle activity in terms of electrical potential, researchers used it for this purpose. In this case, the sensor had two output options: envelope electromyography and amplified raw electromyography signal [26].

The aim of this study was to compare the use of disposable and dry electrodes from the two electromyographic sensor module designs that were made. using root mean square (RMS) to find out the difference in tension generated when lifting the barbell. Numerous studies have used electromyography sensors for prosthetics, robot control, and rehabilitation, according to the aforementioned literature study. In this case, current researchers did not only use electromyography sensors but also created the electromyography sensor itself. Therefore, this research was carried out to make 2 different electromyography module designs and tested the module simultaneously while the biceps muscle lifted the weight. In addition, the difference in amplitude characteristics in the design made was also calculated.

The contribution of this study was to determine the effectiveness of the designs made in our movement trials of this study. Hence, it can be the basis for future research.

**II. Materials and Methods**

**A. Experimental Setup**

For the purpose of this study, data collection was conducted by applying an electrode on the right hand's biceps muscle while the participants sat. In this case, each participant lifted a 3-kilogram weight. Data were collected ten times from 1 respondent. This study used 1 respondent so that the data obtained were homogeneous from the same input for the 3 modules tested. The microcontroller was attached to the electromyography board design, and the data were transmitted via serial communication to the computer. This study used Borland Delphi 7 to record electromyography signal data.

1) Materials And Tools

This collection of home-built electromyography modules was made up of some circuits, including basic devices, notch filters, high pass and low pass filters, and adders. The researcher created two designs for the electromyography module, the second of which used a jack instead of the first's connector. Additionally, scientists created PCB designs for both dry and disposable electrodes and the OY Motion module was used by researchers for the comparison.

2) Experiment

In this experiment, three electromyography modules were used concurrently, and the three outputs from designs 1, 2, and commercial modules were fed into the microcontroller's ADC pin. The signal was further recorded and displayed on a computer.

3) Methods

The electromyography sensor module has the following form. FIGURE 3(a) and FIGURE 3(b) show the connector and jack used in the construction of the Electromyography 1 and Electromyography 2 modules, respectively. Another module, called the dry electrode board, is a supplementary one that used a brass plate for its construction. Despite being a board for disposable electrodes, this board has snap buttons that allow it to be connected to disposable electrodes.

**B. The Diagram Block**

Three electromyography modules were employed in this investigation, as can be seen in the figure below. The circuits included in this block diagram for a homemade electromyography module were basic circuits, notch filters, high pass filters (HPF), and Low Pass Filters (LPF), as well as adders. Through the use of AD620 IC, the fundamental instrument circuit can be used to detect the onset of an electrical signal in a muscle [27][28][29]. In this case, a notch filter was employed to reduce the electric grid's 50 Hz frequency. Researchers passed electromyography frequencies between 20 Hz and 500 Hz using high pass filters (HPF) and Low Pass Filters (LPF) [30]. Op-Amp TL072 was further used in this filter's circuit [31]. Meanwhile, the adder circuit was employed to boost the electromyography signal's reference. The microcontroller's last output from the adder circuit took

a role as an input. Furthermore, in this experiment, three modules were used simultaneously, and each of the three outputs from designs 1, 2, and commercial modules entered the microcontroller's ADC pin. As indicated in FIGURE 1, electromyography data from the three modules were recorded and stored on a personal computer, and signals were viewed on a computer using serial transmission.

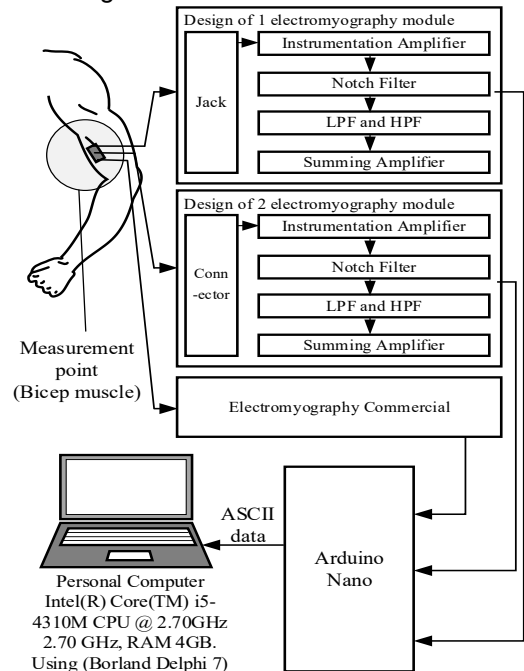

**FIGURE 1. Block Diagram of three channel Electromyography signal detection, 2 channel research board, and 1 commercial channel board**

**C. Flow Chart**

This study's flow chart as presented in FIGURE 2, describes how raw data processed the electromyography to obtain root mean square (RMS) values. In this case, the analog data from the electromyography module was converted into digital data used ADC, and then the data were sent to the computer using serial communication. The data sent to the computer were further recorded and stored for further analysis in .txt format. The data were further used to calculate the value of the root mean square by using python.

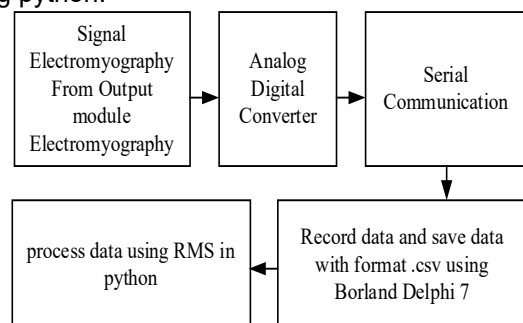

**FIGURE 2. Electromyography raw data processing**

**D. Analog Circuit**

The electromyography sensor module can have the following form. FIGURE 3(a) and FIGURE 3(b) show

the connector and jack used in the construction of the Electromyography 1 and Electromyography 2 modules, respectively. Another module, called the dry electrode board, was the supplementary one that used a brass plate for its construction. Despite being a board for disposable electrodes, this board has snap buttons that allow it to be connected to disposable electrodes.

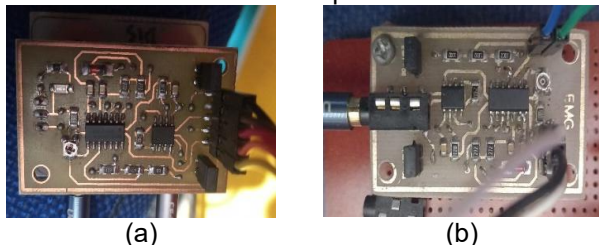

FIGURE 3. Electromyography Design 1 (a) and Electromyography Design 2 (b)

### III. Result

#### A. Techniques for collecting data and measuring points

Data collection in FIGURE 4(a) shows the respondent in a sitting position, while FIGURE 4(b) shows the measurement location on the biceps. The exercise involved lifting a 3 kg barbell to a 90-degree hand position. In this case, the measuring sites for the biceps muscle are shown in FIGURE 4(c).

#### B. Electromyography Circuit

FIGURE 5 is a block circuit where, A0 was connected to the Electromyography board jack on the study's circuit, while A1 was attached to the Electromyography board connector, which was connected to the microcontroller. In this case, the microcontroller's TX and RX were linked to a computer that used serial communication and will read the computer to collect the data.

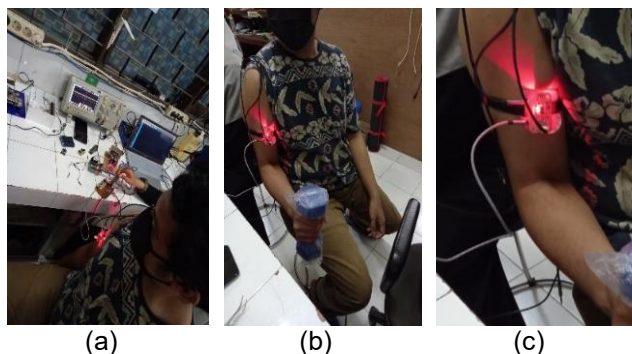

FIGURE 4. (a) Data collection, (b) lifting a barbell while making a 90° turn and (c) Biceps muscle electromyography measurement point

#### C. Data Collected

The respondent sat during the data collection for this investigation, and an electrode was placed on the right hand's biceps muscle. In this case, the one respondent involved lifted a 3 kg weight ten times. Three electromyography signals were collected at the same time and place using simultaneous data retrieval in one motion. The microcontroller was attached to the electromyography board design, and serial communication was used to transmit the data to the

computer. Data from electromyography signals captured with Borland Delphi 7.

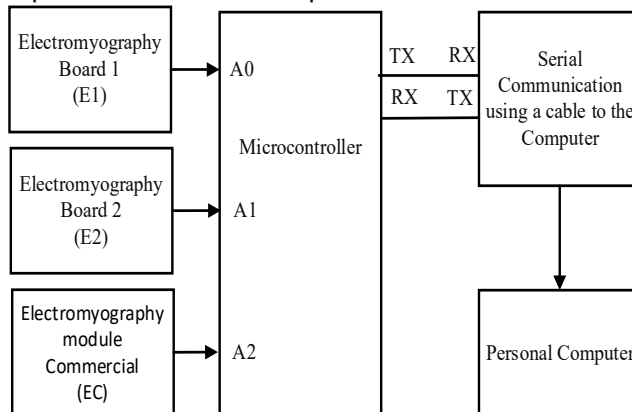

FIGURE 5. The circuit used for electromyography

#### D. Data Processing

The output of the electromyography design built for this study's data processing was sent to pins A0, A1, and A2. The microcontroller converted the output of the electromyography circuit from analog voltage to digital data on pins A0, A1, and A2, which were analog input pins. Root Mean Square (RMS) [32] was used in this study for the time domain-based data adjustment and processing process, and the formula is written in equation 1 (Eq.1):

$$RMS = \sqrt{\frac{1}{N} \sum_{i=1}^N X_i^2} \quad (1)$$

Where  $X_i$  value is data and N is the number of data.

#### E. Result Measurement

In this study, data were collected from ten data collected and calculated using RMS at the time of muscle contraction. The first six combinations, specifically WEE1: Disposable electrode with a series of electromyography 1 board modules, were the potential combination factors that can be examined in this study. Meanwhile, WEE2: Third module of the disposable electrode with electromyography board. WEEC stands for "Disposable Electrode with Commercial Electromyography Board Modules." Furthermore, DEE1 is a dry electrode with electromyography series 1, DEE2 is a dry electrode with electromyography series 2, and DEE3 is a dry electrode with electromyography series 3. In addition, DEEC is a commercial electromyography circuit with a dry electrode. The design trials for the electromyography module 1 (E1), electromyography module 2 (E2), and the commercial module were conducted with the first experiment being the detection of electromyography signals using disposable electrodes. The results are shown in TABLE 1. (EC). The second experiment was conducted using Electromyography Module 1 (E1), Electromyography Module 2 (E2), and Commercial Module Design for Detecting Electromyography Signals Using Dry Electrodes (EC). The electromyography signal acquired from these tests is depicted in FIGURE 6-11.

TABLE 1

Analyze The Intended Design Function.

Board	Electrode type	
	Disposable Electrode	Dry Electrode
E1	WEE1 Figure (6)	DEE1 Figure (9)
E2	WEE2 Figure (7)	DEE2 Figure (10)
EC	WEEC Figure (8)	DEEC Figure (11)

Wet Electrode Design EMG 1

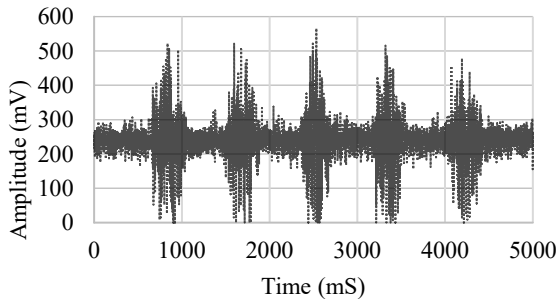

FIGURE 6. Disposable Electrode Connector Design

Disposable Electrode Design EMG 2

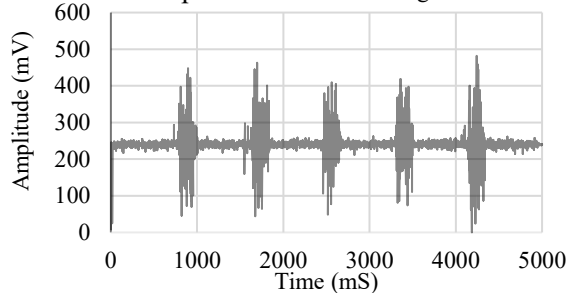

FIGURE 7. Disposable Electrode Jack Design

Disposable Electrode Design EMG Commercial

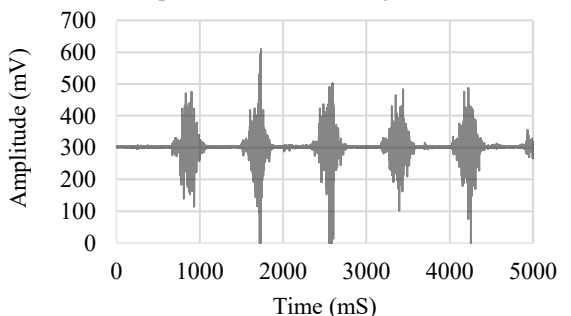

FIGURE 8. Disposable Electrode Design EMG commercial

Dry Electrode Design EMG 1

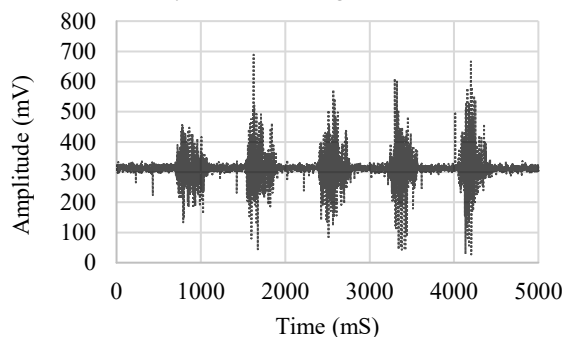

FIGURE 9. Dry Electrode Connector Design

Dry Electrode Design EMG 2

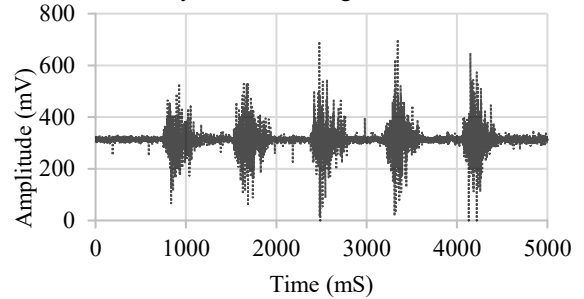

FIGURE 10. Dry Electrode Jack Design

Dry Electrode Design EMG Comercial

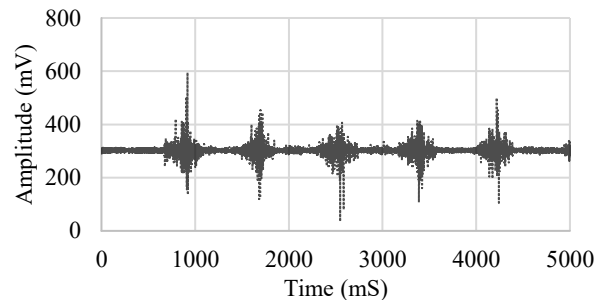

FIGURE 11. Dry Electrode of commercial

All design tools created from data collection were capable of accurately detecting electromyography signals either utilizing dry electrodes or disposable electrodes, both employing E1 and E2 designs. In this case, the authors assessed the amplitude produced by each design using the results of these data. At the time of data collection, disposable electrodes were used on two designs, namely, design 2 (WEE2) and design 1 (WEE1) that received amplitude results with amplitude ratios of 180 mV and 170 mV, respectively. This information is shown in table 2 regarding data amplitude ratios that increased for each design created. On the other hand, during the data collection, dry electrodes were used together with two different design types, resulting in design 2 (DEE2) obtaining an amplitude with a rate-of-change value of 210 mV, while design 1 (DEE1) obtained a rate-of-change value of 200mV. Compared to commercially produced designs using dry electrodes yielded results of approximately 100 mV, whereas commercially produced designs using disposable electrodes yielded results of approximately 130 mV. The following TABLE 2 displays the analysis's results.

Table 2

Electromyography Signal Data Analysis On 1 Jack Design, 2 Connector Designs, And Commercial Module

Electromyography design in research			
Design Board	Mean RMS using Disposable Electrode (WE)	Mean RMS using Dry Electrode (DE)	Difference
E1	180 mV	210 mV	30 mV
E2	170 mV	200 mV	30 mV
EC	130 mV	100 mV	30 mV

#### F. Statistics Analysis

To get the amplitude value in this study, the average value of the data collected was calculated. In this case, the T-Test is also used to run new tests on the 10 data points that have been collected. the p-value of the T-test when using disposable electrodes from both electromyography module 1 (WEE1) and electromyography module 2 (WEE2) designs was 0.001766368 less than 0.05. The p-value of the T-test of the two electromyography modules when using dry electrodes design the electromyography module 1 (DEE1) and electromyography module 2 (DEE2) of 0.001766368, which is less than 0.05. it can be concluded that there is a significant difference.

#### IV. Discussion

When testing the data using the design and disposable electrodes, the resulting design produced an average amplitude of 170 mV, while the jack design produced an average amplitude of 180 mV. Meanwhile, after testing the data using the dry electrodes and two designs, namely the jack design and the connector design, the average amplitude was 210 mV for the jack design and 200 mV for the connector design. The amplitude obtained in the commercial design using a dry electrode board obtained an average result of 100 mV, and the commercial design using a disposable electrode board obtained an average result of 130 mV when compared to the commercial design. Based on the results of the t-test, there was no difference found between the E1 and E2 modules when using disposable electrodes compared to using dry electrodes. However, there was a difference in the amplitude. Meanwhile, table 2 shows that the use of dry electrodes resulted in a higher average amplitude, while the use of disposable electrodes resulted in a difference of 30mV.

Seong Ho Yeon et al investigated dry electrodes using Flexible Flat Cable (FFC) when recording electromyographic signals and the researchers analyzed the on and off-time responses of muscle contraction [20]. Ernest N. Kamavuako et al further investigated the performance comparison using gel electrodes and dry electrodes through 9 different hand movements. The researcher said that the performance of the dry electrode achieved almost the same result as the performance of the gel electrode [21]. Furthermore, Daxiu Tang et al investigated the traditional three-layer sEMG electrode material which had high conductivity, low yield electrode impedance, excellent strain intensity, high fatigue resistance, and good skin compatibility compared to other copper Ag/AgCl and AgCl electrodes. [22].

The limitation of this research is that based on the design proposed in this study, weaknesses were also found, namely the use of cables that interfered with data collection. In addition, the method proposed for analysis in this study has not been shown in real time so it still took a long time to analyze. Furthermore, the use of dry electrodes had a greater range of amplitude differences

compared to the use of disposable electrodes. When viewed from the method of data collection, this study also only did one movement. So the author cannot know which design is best to support multiple movements.

The implication of this research is that the design of the electromyography module can be used as a learning and research activity to record electromyographic signal data by choosing the best design for the movement performed by the object.

#### V. Conclusion

A number of studies have used electromyography sensors for prosthetics, robot control, and rehabilitation. Hence referring to those previous studies, this research is carried out through the making of two different electromyography module designs and tested these modules simultaneously while the biceps lifted weights. In addition, this research was also done to determine the differences in amplitude characteristics in the design of the electromyography module and to determine the effectiveness of the design made in the weightlifting experiment.

In this study, disposable electrodes (WE) and dry electrodes (DE) were used to compare the designs of electromyography sensor modules 1 (E1) and 2 (E2). Furthermore, it was found that the amplitude of the design made in this study was greater than the amplitude produced by a commercial electromyography (EC) module. In addition, the use of dry electrodes is more common than the use of disposable electrodes in modules 1 and 2 designs. However, the use of dry electrodes in commercial electromyography modules is less common than that of disposable electrodes. the p-value of the T-test when using disposable electrodes from both electromyography module 1 (WEE1) and electromyography module 2 (WEE2) designs was 0.001766368 less than 0.05. The p-value of the T-test of the two electromyography modules when using dry electrodes design the electromyography module 1 (DEE1) and electromyography module 2 (DEE2) of 0.001766368, which is less than 0.05. Therefore, it can be concluded that there is a significant difference between the WEE1 : WEE2 module tests. and between DEE1 : DEE2. from the data as outlined in TABLE 2 there is an average amplitude difference of 10mV between the E1 and E2 modules when using both types of electrodes. and there is an average amplitude difference between when using dry and disposable electrodes of 30mV. It can be concluded that there are significant differences.

The next researcher is further expected to create a wireless electromyography sensor module using a design for an electromyography sensor, thus enabling the measurement of muscle signals during walking motions.

#### References

- [1] W. Rose, "EMG Analysis," *J. Math. Signal Process. Biomech.*, pp. 1–10, 2019.

- [2] K. Samarawickrama, S. Ranasinghe, and Y. Wickramasinghe, "Surface EMG Signal Acquisition Analysis and Classification for the Operation of a Prosthetic Limb," *Int. J. Biosci. Biochem. Bioinforma.*, vol. 8, no. August, 2018, doi: 10.17706/ijbbb.2018.8.1.32-41.
- [3] J. Pauk, "Different techniques for EMG signal processing," *J. VIBROENGINEERING*, vol. 10, no. 4, pp. 571–576, 2008.
- [4] M. Patidar, "Classification of Normal and Myopathy EMG Signals using BP Neural Network," *Int. J. Comput. Appl.*, vol. 69, no. 8, pp. 12–16, 2013.
- [5] W. Xu, "Research on EMG Signal Extraction Based on Biomimetic Hand," *Int. Conf. Manag. Educ. Inf.*, vol. 156, no. Meici, pp. 786–790, 2017.
- [6] N. B. Mohammed, A. A. Saeed, and A. M. Ahmed, "Statistical Modeling of EMG Signal," *Int. J. Eng. Appl. Sci.*, no. 10, pp. 41–45, 2016.
- [7] K. M. Peters, V. E. Kelly, T. Chang, M. C. Weismann, S. Westcott, and K. M. Steele, "Muscle recruitment and coordination during upper-extremity functional tests," *J. Electromyogr. Kinesiol.*, vol. 38, no. November 2017, pp. 143–150, 2018.
- [8] C. Seguna, A. Von Brockdorff, J. Scerri, and K. Scicluna, "Classification of Five Finger Movement, based on a Low-cost, Real-time EMG System," *Int. Conf. Biomed. Electron. Devices*, vol. 1, no. Biostec 2020, pp. 149–159, 2022, doi: 10.5220/0008978901490159.
- [9] S. Singh, "Electromyography (EMG) based signal processing and their Feature Selection using Wavelet Transform," *Int. J. Appl. Eng. Res.*, vol. 14, no. 2, pp. 215–220, 2019.
- [10] E. Farago, S. Chinchalkar, D. J. Lizotte, and A. L. Trejos, "Development of an EMG-Based Muscle Health Model for Elbow Trauma Patients," pp. 1–15, 2019, doi: 10.3390/s19153309.
- [11] J. A. Ruvalcaba, M. I. Gutiérrez, A. Vera, and L. Leija, "Wearable Active Electrode for sEMG Monitoring Using Two-Channel Brass Dry Electrodes with Reduced Electronics," *J. Healthc. Eng.*, vol. 2020, 2020, doi: 10.1155/2020/5950218.
- [12] C. Pylatiuk *et al.*, "Comparison of surface EMG monitoring electrodes for long-term use in rehabilitation device control," *2009 IEEE Int. Conf. Rehabil. Robot. ICORR 2009*, no. May 2014, pp. 300–304, 2009, doi: 10.1109/ICORR.2009.5209576.
- [13] A. G. S. Rayo *et al.*, "Design and manufacturing of a dry electrode for EMG signals recording with microneedles," *Adv. Struct. Mater.*, vol. 72, pp. 259–267, 2018, doi: 10.1007/978-3-319-59590-0\_22.
- [14] M. Yamagami *et al.*, "Assessment of dry epidermal electrodes for long-term electromyography measurements," *Sensors (Switzerland)*, vol. 18, no. 4, pp. 1–15, 2018, doi: 10.3390/s18041269.
- [15] A. Paiva, H. Carvalho, A. Catarino, O. Postolache, and G. Postolache, "Development of dry textile electrodes for electromyography a comparison between knitted structures and conductive yarns," *Proc. Int. Conf. Sens. Technol. ICST*, vol. 2016-March, pp. 447–451, 2016, doi: 10.1109/ICSensT.2015.7438440.
- [16] Y. Fu, J. Zhao, Y. Dong, and X. Wang, "Dry electrodes for human bioelectrical signal monitoring," *Sensors (Switzerland)*, vol. 20, no. 13, pp. 1–30, 2020, doi: 10.3390/s20133651.
- [17] M. S. Rodrigues *et al.*, "Dry electrodes for surface electromyography based on architected titanium thin films," *Materials (Basel)*, vol. 13, no. 9, 2020, doi: 10.3390/ma13092135.
- [18] X. Zeng, Y. Dong, and X. Wang, "Flexible electrode by hydrographic printing for surface electromyography monitoring," *Materials (Basel)*, vol. 13, no. 10, pp. 1–10, 2020, doi: 10.3390/ma13102339.
- [19] Y. Dassoivre, C. Barthod, and M. Passard, "Implementation of new dry electrodes and comparison with conventional Ag/AgCl electrodes for whole body electrical bioimpedance application," *Proc. Annu. Int. Conf. IEEE Eng. Med. Biol. Soc. EMBS*, vol. 2015-Novem, pp. 6864–6867, 2015, doi: 10.1109/EMBC.2015.7319970.
- [20] R. G. Scalisi *et al.*, "Inkjet printed flexible electrodes for surface electromyography," *Org. Electron.*, vol. 18, pp. 89–94, 2015, doi: 10.1016/j.orgel.2014.12.017.
- [21] A. M. Naim, K. Wickramasinghe, A. De Silva, M. V. Perera, T. D. Lalitharatne, and S. L. Kappel, "Low-cost Active Dry-Contact Surface EMG Sensor for Bionic Arms," *Conf. Proc. - IEEE Int. Conf. Syst. Man Cybern.*, vol. 2020-October, pp. 3327–3332, 2020, doi: 10.1109/SMC42975.2020.9283285.
- [22] P. Laferriere, E. D. Lemaire, and A. D. C. Chan, "Surface electromyographic signals using dry electrodes," *IEEE Trans. Instrum. Meas.*, vol. 60, no. 10, pp. 3259–3268, 2011, doi: 10.1109/TIM.2011.2164279.
- [23] B. Champaty, P. Dubey, S. Sahoo, S. S. Ray, and K. Pal, "rehabilitation devices," in *International Conference on Magnetism, Machines & Drives (AICERA-2014 ICMMDD)*, 2014, pp. 3–6. doi: 10.1109/AICERA.2014.6908260.
- [24] S. S. Lee, K. Y. Shin, and J. H. Mun, "Development of a Pre-amplifier and a Wireless Surface EMG," vol. 14, pp. 2748–2751.
- [25] T. George, S. G. K, and K. S. Sivanandan, "Sensing, Processing and Application of EMG signals for HAL (Hybrid Assistive Limb)," no. Seiscon, pp. 749–753, 2011.
- [26] F. Ali, J. Sintang, M. Aras, and A. Zakishukor, "Design and Construction of 4-DOF EMG-Based Robot Arm System," no. 12, pp. 669–674, 2019, doi: 10.35940/ijitee.L1116.10812S219.
- [27] F. Sadikoglu, C. Kavalcioglu, and B. Dagman, "Electromyogram (EMG) signal detection, classification of EMG signals and diagnosis of neuropathy muscle disease," *Procedia Comput. Sci.*, vol. 120, pp. 422–429, 2018, doi: 10.1016/j.procs.2017.11.259.
- [28] A. Salman, J. Iqbal, U. Izhazhar, U. S. Khan, and N. Rashid, "Optimized circuit for EMG signal processing," *2012 Int. Conf. Robot. Artif. Intell. ICRAI 2012*, no. October, pp. 208–213, 2012, doi: 10.1109/ICRAI.2012.6413390.
- [29] R. Sayyed, N. Akhter, A. Khan, and G. Rabbani, "Remote monitoring of EMG signals," *Int. J. Res. Anal. Rev.*, vol. 6, no. 2, pp. 135–141, 2019, doi: 10.1729/Journal.20838.
- [30] Ahmad Kamil Solihin, Endro Yulianto, Her Gumiwang Ariswati, and K. K. M. Rahman, "Design of an Electromyograph Equipped with Digital Neck Angle Elevation Gauge," *J. Electron. Electromed. Eng. Med. Informatics*, vol. 3, no. 3, pp. 141–148, 2021, doi: 10.35882/jeemi.v3i3.4.
- [31] R. Ismail, "Muscle Power Signal Acquisition Monitoring Using Surface EMG," *J. Biomed. Res. Environ. Sci.*, vol. 3, no. 5, pp. 663–667, 2022, doi: 10.37871/jbres1493.
- [32] T. Triwiyanto *et al.*, "Electromyography Feature Analysis to Recognize the Hand Motion in a Prosthetic Hand Design," *J. Biomimetics, Biomater. Biomed. Eng.*, vol. 50, pp. 25–37, 2021, doi: 10.4028/www.scientific.net/JBBBE.50.25.